

Township of Barnegat

COUNTY OF OCEAN



WATER & SEWER UTILITIES
900 WEST BAY AVENUE
BARNEGAT, NEW JERSEY 08005-1298

OFFICES: (609) 698-6185
FAX #: (609) 698-6223
Visit Our Website: www.barnegatwatersewer.com

BARNEGAT WELL #3 WATER TREATMENT TANK

(1) 650 gallon nominal lime mix tank constructed with A36 carbon steel and consisting of:

- Dimensions: 5'--0" Diameter X 4'-7" Straight Height
- Shell Thickness: 1/4" Plate A36
- Bottom: 1/4" Plate A36 Flat
- Cover: 1/4" Plate A36 with one (1) Polypropylene hinged cover opening
- Legs: 4" X 4" X 3/8" A36 Angle with 3/4" A36 Bottom Pads
- Baffles: Qty-4 - 1/4" X 6" Wide A36
- Lifting Lugs: Qty. - 2 - 1/4" A36

Accessories included:

- Two (2) tank stands -6" High
- One (1) 2" coupling -Sidewall/ Low -Sidewall Drain
- One (1) 2" coupling -Top -Water makeup entry
- Two (2) 2" coupling with PVC stilling well -Top -Pump suction
- One (1) 13" access opening (with bolted cover) for enhanced Mixer shaft & prop access
- One (1) 3" connection pipe -Top -Dust collector

1 Finish

Tank Interior to be Mill Finish

Tank Exterior & Pump Stand

One (1) coat Amerlock 600, OFT+ 5-1 O mils

One (1) Coat PittThane Ultra, OFT 2-3 mils, Final OFT 7-13 mils

TOTAL PRICE: F.O.B. points of origin with full freight allowed to jobsite \$ _____

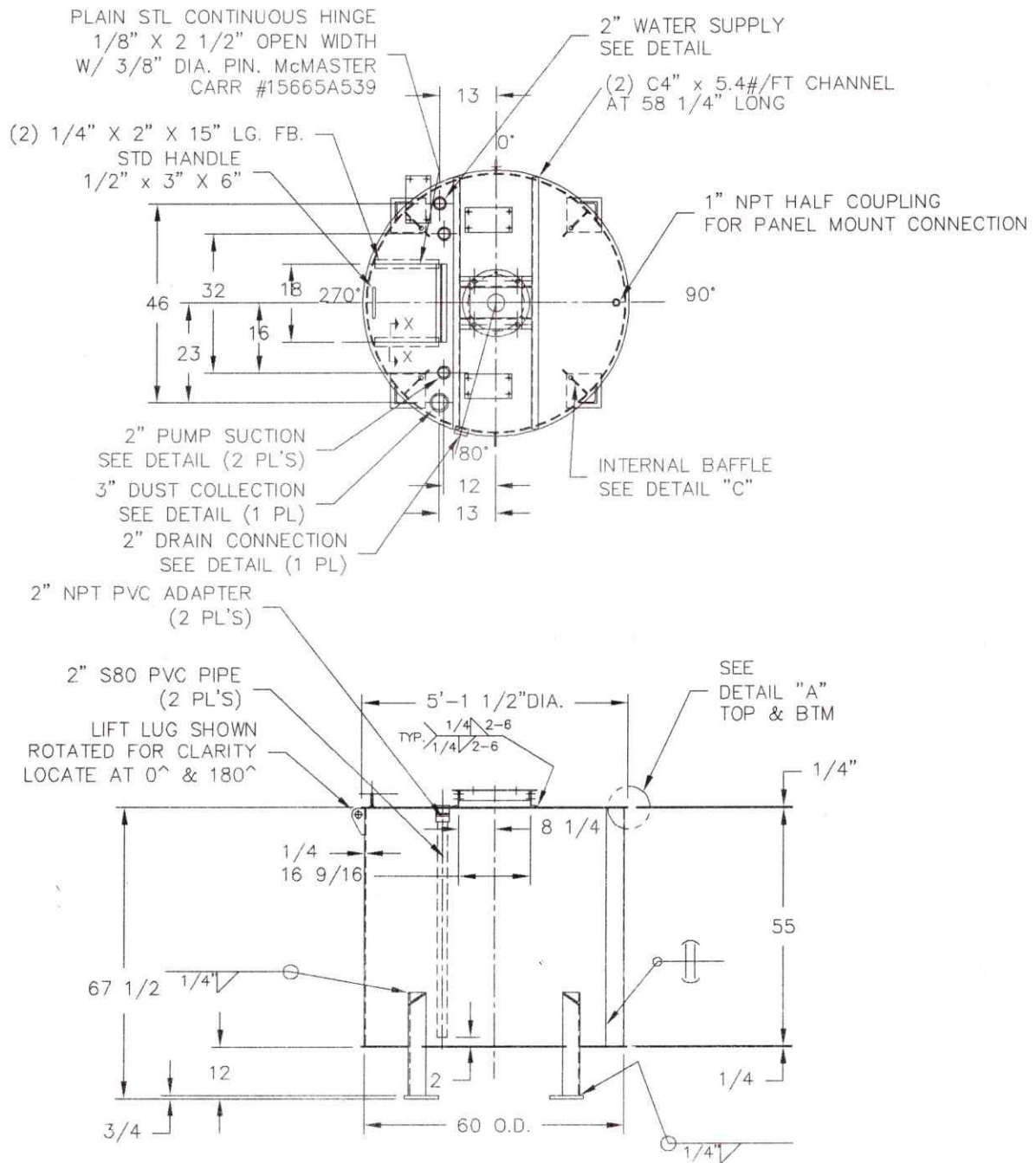

WELL #3 TANK