

**RULES AND REGULATIONS  
FOR THE  
SANITARY SEWER SYSTEM**

**TOWNSHIP OF BARNEGAT  
OCEAN COUNTY, NEW JERSEY**

February 2014

TOWNSHIP OF BARNEGAT  
SANITARY SEWER SYSTEM  
RULES AND REGULATIONS

TABLE OF CONTENTS

I.	INTRODUCTION AND GENERAL INFORMATION	<u>PAGE</u>
	A. Introduction and Purpose	I-1
	B. Township Municipal Building	I-1
	C. Definitions	I-1
	D. Conditions Requiring the Installation of Sanitary Sewer Facilities	I-4
II.	SEWER SYSTEM STANDARDS FOR SUBDIVISIONS AND DEVELOPMENTS	
	A. Requirements	II-1
	B. Procedures	II-3
	C. Detailed Requirements of Applications	II-5
III.	SEWER SYSTEM STANDARDS FOR CONNECTIONS OTHER THAN DEVELOPMENTS - INDIVIDUAL CONNECTIONS	
	A. Residential Connections	III-1
	B. Commercial and Industrial Connections	III-1
	C. Requirements – Individual House Connections	III-2
	D. Procedure – Individual House Connections	III-3
	E. Materials – Individual House Connection	III-4
	F. Requirements – Large Commercial and Industrial Units	III-4
	G. Procedures – Large Commercial and Industrial Units	III-5
	H. Materials – Large Commercial & Industrial Units	III-7
IV.	DETAILED SPECIFICATIONS FOR SANITARY SEWER CONSTRUCTION	
	A. Introduction and Purpose	IV-1
	B. General Requirements	IV-1
	C. Permits and Fees	IV-1
	D. Standard Technical Specifications for Construction of Sanitary Sewers	IV-2
	1. General Information	IV-2
	1.00 Quality of Materials and Workmanship	IV-2
	1.01 Sequence of Construction Operations and Time Schedule	IV-2
	1.02 Lines and Grades	IV-2
	1.03 Leakage	IV-3

1.04	Clean Up	IV-3
1.05	Certificate of Insurance	IV-3
1.06	Dewatering Facilities	IV-4
1.07	Markers for Branch Connections on Sewers	IV-5
1.08	Maintaining Streets During and Subsequent to Construction	IV-5
1.09	New Developments	IV-5
2.	General Specifications	IV-5
2.00	Equivalent Materials and Equipment	IV-5
2.01	Materials and Workmanship	IV-5
2.02	Equipment	IV-6
2.03	Construction Schedule	IV-6
2.04	Shop or Setting Drawings	IV-6
2.05	Sanitary Regulations	IV-8
2.06	Cleaning Up	IV-8
2.07	Explosives	IV-8
2.08	Special Requirements in and Adjacent to County Roads	IV-9
2.09	Open Excavation, Safety Barricades, Watchmen	IV-9
2.10	Tree Protection and Tree Removal	IV-9
2.11	Trench Consolidation, Backfill, Clean-up and Traffic Maintenance	IV-10
2.12	Pavement Replacement	IV-10
2.13	Control and Protection of Traffic at Construction Sites	IV-10
2.14	Notification of Utility Companies	IV-11
3.	Technical Specifications	IV-11
3.00	Excavation	IV-11
3.01	Unauthorized Excavation	IV-12
3.02	Sheeting and Bracing	IV-12
3.03	Drainage and Dewatering	IV-12
3.04	Topsoil	IV-13
3.05	Backfill & Suitable Backfill	IV-13
3.06	Trench Widths	IV-13
3.07	Buried Utilities and Structures	IV-14
3.08	Over Excavation	IV-14
3.09	Excavation and Protection of Property	IV-15
3.10	Backfill in Trench	IV-15
3.11	Disposal of Material	IV-16
3.12	Temporary Bridges and Crossings	IV-16
3.13	Work in Lawn Areas	IV-17
3.14	Bedding	IV-17
3.15	Pipe Materials	IV-19
3.16	Pipe Linings and Coatings	IV-22
3.17	Pipe Installation	IV-23

3.18	Pipe Tests and Inspection	IV-24
3.19	Manholes	IV-27
3.20	Cast-in-Place Concrete	IV-31
4.	Technical Specifications – Pumping Stations	IV-33
4.00	General	IV-33
4.01	General Description	IV-34
4.02	Operating Conditions	IV-35
4.03	Miscellaneous Section	IV-36
4.04	Field Tests	IV-37

V. STANDARDS CONSTRUCTION DETAILS

Precast Concrete Manhole	V-1
Manhole Notes	V-2
Standard or Watertight Manhole Frame and Cover	V-3
Inside Drop Connection (Existing Manhole)	V-4
Outside Drop Connection	V-5
House Lateral and Stub at Manholes	V-6
Shallow Manhole	V-7
Cleanout Protection Box	V-8
Concrete Encasement	V-9
Polypropylene Manhole Step	V-10
Manhole Channels	V-11
Lateral Service Connection	V-12
Deep House Connection	V-13
Manhole Chute	V-14
PVC Pipe Ordinary Pipe Bedding	V-15
Class “A” Modified Concrete Cradle Bedding	V-16
Class “A-1” Modified Concrete Cradle Bedding	V-17
Class “A-2” Modified Concrete Arch Bedding	V-18
Required Backfill and Compaction	V-19
Grease Monitoring Pit	V-20
1,000 Gal. Grease Trap	V-21
Inserta-Tee Connection	V-22

VI. STANDARDS FOR ACCEPTABLE WASTES VI-1

VII. APPLICATION AND PERMIT FORMS

Exhibit A – Deed of Easement and Right-of-Way	VII-1
Exhibit B – Application for Review of Preliminary Plans for Sanitary Sewerage Facilities	VII-3
Exhibit C – Application for Review of Final Plans for Sanitary Sewerage Facilities	VII-6
Exhibit D – Application for Certification of Completion for Sanitary Sewerage Facilities	VII-10

Exhibit E – Bill of Sale/Resolution of Sale	VII-12
Exhibit F – Contractors Affidavit	VII-14
Exhibit G – Corporate Resolution	VII-15
Exhibit H – Application for Individual Sewer Connection	VII-16

APPENDIX I – SCHEDULE OF EQUIVALENT DWELLING UNITS

APPENDIX II – FEE SCHEDULE

# I. INTRODUCTION AND GENERAL INFORMATION

## RULES AND REGULATIONS

### I. INTRODUCTION AND GENERAL INFORMATION

#### A. INTRODUCTION AND PURPOSE

These rules and regulations have been established to facilitate the review of applications to the Township of Barnegat for the construction of Sanitary Sewerage Facilities.

All individual property owners, as well as subdividers and developers of residential, commercial or industrial properties, are required by Resolution of the Township to submit applications for all phases of planning, design, and construction of Sanitary Sewerage Facilities. Applications for review as well as governing rules and regulations are required to provide for the unified and systematic construction of collection and treatment facilities within the Township. The need for these rules and regulations are further strengthened by the imperative to foster and promote the protection of the water course of the Township of Barnegat to abate pollution, and to provide for the public welfare. All residential subdivisions and developments receiving preliminary subdivision or site plan approval after June 3, 1997 are also required to follow the requirements promulgated in the Residential Site Improvement Standards (RSIS), N.J.A.C. 5:21, incorporated herein.

#### B. TOWNSHIP MUNICIPAL BUILDING

1. The principal office of the Township and place of business is located at 900 West Bay Avenue, Barnegat, New Jersey 08005.
2. Application for review of Plans, Permit Application, and payment of fees, shall be made at the Township Municipal Building and to the Township Clerk.
3. The Township Clerk will be available at the Township Municipal Building for the purpose of official business from Monday through Friday, between the hours of 8:30 a.m. to 4:30 p.m., prevailing time except on legal holidays.

#### C. DEFINITIONS

Unless the context of these rules and regulations specifically indicates otherwise, the following meanings shall apply as indicated hereafter:

1. "Applicant" shall mean the individual, corporation, partnership or authorized agent making application to the Township.
2. "As Built" shall mean a record of the Sanitary Sewerage Facilities, as constructed.

3. "B.O.D." (Biochemical Oxygen Demand) shall mean the quantity of oxygen utilized in the biochemical oxidation of organic matter under standard laboratory procedure in five (5) days at twenty (20) degrees Centigrade, expressed in parts per million by weight, or milligrams per liter.
4. "Building Sewer" or "house connection" shall mean the extension from a commercial, institutional or industrial building or buildings to the Township's sewer.
5. "Clerk" or "Township Clerk" shall mean the duly appointed Clerk of the Township.
6. "Commercial Concern" shall mean any concern engaged in service, trade, business, traffic or commerce in general, exclusive of Industrial concerns.
7. "Developer" shall mean the legal or beneficial owner or owners of a lot or of any land proposed to be included in a proposed development, including the holder of an option or contract to purchase, or other person having an enforceable proprietary interest in such land.
8. "Development" shall mean the division of any parcel of land into two or more parcels; the construction, reconstruction, conversion, structural alteration, relocation, or enlargement of any building or other structure, or of any mining, excavation, or landfill; and any use or change in the use of the building or other structure, or land, or extension of use of land, for which permission may be required per the Municipal Land Use Law.
9. "Equivalent Dwelling Unit or EDU" shall mean the number of equivalent single family units derived by dividing the total anticipated daily sewer flow for a proposed use by that generated by a typical single family dwelling (See Barnegat Township Code, Chapter 74, Water/Sewer Utility, for standard flow established for an equivalent dwelling unit/singe family dwelling). Portions of an EDU are rounded up to the next whole unit.
10. "Estimated Project Cost" shall mean the estimated cost of construction, right of ways, easements, engineering, bonds, insurance, legal and administrative services.
11. "Garbage" shall mean solid wastes from the domestic and commercial preparation, cooking and dispensing of food and from the handling, storage and sale of produce. "Properly Shredded" garbage shall mean solids, which have been shredded to such a degree, that all particles will be carried freely under the flow conditions normally prevailing in public sewer, with no particle greater than one-half inch in any dimension.
12. "Industrial Concern" shall mean any concern engaged primarily in manufacturing or processing operations.



13. "Industrial Waste" shall mean the liquid wastes from industrial and manufacturing processes, trade or business. (See Sewage).
14. "Lateral" or "sewer branch connection" shall mean any pipe together with necessary connections conveying sewage from the "building sewer" at either the curb line or Township's easement line to the sewerage system.
15. "May" means permissive - "shall," means mandatory.
16. "Owner" shall mean the property upon whose behalf an application for water or sewer connection is made to the Township.
17. "pH" shall mean the logarithm of the reciprocal of the weight of hydrogen ions in grams per liter of solution, and is the measure of acidity or alkalinity.
18. "Planning Board" shall mean the Planning Board of the Township of Barnegat as created under State statute.
19. "Plumbing Inspector" shall mean the person duly designated by the Township as the subcode official administering the "State Uniform Construction Code Act."
20. "Pumping Station" shall mean a permanent facility constructed to convey sewage to another sewer by pumping, rather than by gravity, or to boost water pressure by pumping.
21. "Professional Engineer" shall mean a person licensed to practice Professional Engineering in the State of New Jersey.
22. "Sanitary Sewer" shall mean any pipe conduit used to collect and carry away sewage from the generating source to treatment plants.
23. "Sewage" shall mean a combination of the water carried wastes from residence, business buildings, institutions, industrial establishments, and other buildings or places. (See Industrial Waste).
24. "Sewage Treatment Plant" shall mean any arrangement of devices and structures used for the treating of sewage in the Township other than that used on and for one property under one ownership as an individual sanitary disposal system.
25. "Sewer System" shall mean all trunks, sub-trunks, sewers, interceptors, laterals, branches, and all other sewer appurtenances, owned by the Township.
26. "Slug" shall mean any discharge of water, sewage or industrial waste which is concentrated of any given constituent or if quantity of flow

exceeding any period of duration longer than sixty (60) minutes, more than four (4) times the average daily concentration of flows during a normal operational day.

27. "Street" shall mean any and all streets, avenues, highways, and roads, whether publicly used or dedicated with or without acceptance by the Township, County or State.
28. "Subdivision-Major" shall mean any subdivision not classified as a minor subdivision.
29. "Subdivision-Minor" shall mean a subdivision of land for the creation of a number of lots specifically permitted by ordinance as a minor subdivision, provided that such subdivision does not involve a planned development, any new street, or the extension of any off-tract improvement, the cost which is to be prorated pursuant to N.J.S.A. 40:55D-42.
30. "Suspended Solids" shall mean solids that either float on the surface, or are in suspension in water, sewage, or other liquids and which are removable by laboratory filtering.
31. "Township" shall mean the Township of Barnegat in the County of Ocean, State of New Jersey.
32. "Township Water and Sewer Engineer" shall mean the Consulting Engineer duly authorized by the Township to review and inspect all Water System and Sewer System Facilities.
33. "Township Sewer" shall mean a sewer owned by the Township in public streets or easements including laterals to two feet behind the curb line or edge of the easement.

D. CONDITIONS REQUIRING THE INSTALLATION OF SANITARY SEWERAGE FACILITIES

Pursuant to Ordinance of the Barnegat Township Board of Health, the owner of every house, building or structure, now or hereafter constructed, assembled or moved onto any lot in the Township of Barnegat, intended for residential, industrial or commercial use or professional occupancy located on any street along the line of any public or private sewer system now or hereafter constructed, where such house, building or structure is located not more than 200 feet from the line of such public or private sewer system, shall connect to the nearest Township line.

In the event that the applicant's lands are deemed by the Township to be too remote from an existing sanitary sewer, one of the following methods of sewage disposal will be required as determined by the Township:

- 1) Sanitary sewer system and pump station.
- 2) Dry sanitary sewer system for future use and individual sewage disposal systems on each lot.
- 3) Individual sewage disposal systems.

The Township establishes herein a review procedure for proposed sanitary sewerage facilities regulated through an application system.

Owners of property connected to the Township's sewerage system shall inform the Township in writing of the change in ownership and of any change in the nature of the wastewater discharged to the sewers.

All proposed facilities that connect or shall connect to a Township Sanitary Sewer as hereinbefore listed, as well as other special units which do not fall into a listed section, shall be required to file a written application for Review in accordance with one of the following sections:

- II. Rules and Regulations – Sewer System Standards for Subdivisions and Developments.
- III. Rules and Regulations – Sewer System Standards for Connections other than Subdivisions and Development – Individual Connections.

## II. SEWER SYSTEM STANDARDS FOR SUBDIVISIONS AND DEVELOPMENTS

## II. SEWER SYSTEM STANDARDS FOR SUBDIVISIONS AND DEVELOPMENTS

### A. REQUIREMENTS

1. Approval of all sanitary sewerage facilities is required for all proposed subdivisions and developments in the Township.
2. Each proposed subdivision and development must meet the standards and specifications of the Township as well as any and all relevant ordinances of the Township, as well as any state or federal regulation.
3. Each subdivision or development shall install a sanitary collection system with at least one house connection provided for each lot. In condominium or cooperative developments where there are no lot lines or in garden apartment house projects for rental, at least one building connection shall be provided for each structure. The size of the building connection will be based upon the number of fixture units as determined by the Building Code of the Township; however, in no event shall the building sewer be less than 4" in diameter.
4. When plans for future development necessitate oversizing or grade changes, the developer may enter into a developers agreement with the Township to address the fair share of costs of the improvements above those required for the operation of sewer systems within the development.
5. In areas removed from the existing Township collection system, the Township shall decide as to whether the proposed system shall be connected to the existing Township sanitary sewer or approve an interim treatment facility.
6. Pumping stations, interceptor or trunk lines must receive specific Township approval.
7. For those locations which are remote from an existing sewer, the Township shall decide the most suitable method for providing sanitary service; either through the construction of an extension to an existing Township sewer or by the construction of state approved Interim Treatment Plant. The Township shall review the cost of a sewer extension or interim treatment plant to service the proposed facilities of the applicant during the preliminary review period. If it is determined that the extension of an existing Township sewer or interim treatment plant is the most practical means available to provide service, then the Township will notify the applicant. The applicant shall perform the engineering design and construction of the required sewerage facilities.
8. As used herein, the term "estimated project cost" shall mean that amount determined in accordance with industry standards which will be required to be expended by the Township in the event the applicant fails to

perform. Said estimating shall be subject to current construction costs and per specific site conditions.

9. All required easements in approved form and executed by the property owner and other parties of interest shall be submitted in the exact form shown in Exhibit A.
10. The Township will perform inspection of the construction of sewerage facilities, including sewers, pumping stations, treatment plants and appurtenances.
11. As-built plans (plan and profile) acceptable to the Township ~~Water~~ and Sewer Engineer must be submitted to the Township prior to the ~~sanitary sewer~~ system being placed into operation. Upon completion of all the work in the development and prior to the release of the performance bond, the applicant shall submit digital copies of the ~~as-built utility plans for approval~~. Digital copies shall be geo-referenced relative to the NJ State Plane Coordinate System. Utility as-builts shall identify the actual field location of all installed utilities. Offsets dimensions (from curb, edge pavement, or easement line) shall be supplied for ~~water~~ mains. As-builts shall reflect the addition or deletion of bends as installed in the field. Building service connections shall be triangulated to nearest identified building corners and provided in a tabulated form.
12. Each construction plan must contain the following approval block on the original reproducible.

- Deleted: B
- Deleted: Water
- Deleted:
- Deleted: water
- Deleted: A
- Deleted: A
  
- Deleted: water

SANITARY SEWERAGE FACILITIES  
APPROVED BY THE TOWNSHIP OF BARNEGAT

\_\_\_\_\_  
Township Engineer

\_\_\_\_\_  
Date

13. Where applicable, a State of New Jersey Department of Environmental Protection Treatment Works Approval Permit shall be obtained by the Applicant prior to start of construction. Permits to construct sewers and/or other structures within right-of-way limits of State, County, and Municipal roads must be secured and paid for by the Applicant.
14. All design and work shall conform to the requirements of the Township Rules and Regulations and N.J.A.C. 7:14A-22 and 7:14A-23.
15. Connection Fees and Equivalent Dwelling Units shall be calculated in accordance with the Schedule of Equivalent Dwelling Units and the Fee Schedule.

B. PROCEDURES

1. The applicant may obtain a copy of the "Rules and Regulations" at the Township Municipal Building together with all pertinent application forms. The applicant shall complete the appropriate forms for either review of preliminary plans or for review of final plans and specifications. Applications are as follows:

- a. Application for Review of Preliminary Plans

An application in proper form for Review of Preliminary Plans in the exact form shown in Exhibit "B" shall be submitted to the Township together with the required fees.

The review by the Township Engineer will, in general, determine the following information:

- 1) The extent and scope of the facilities required.
- 2) The acceptable outlet for the development or subdivision either by the construction of an extension to a Township sewer or by the construction of an interim treatment facility.

The review period for preliminary plans shall be consistent with the extent of the subdivision or development submitted. In general, this period will not extend beyond sixty (60) days from the date of acceptance for review unless extenuating circumstances require an extension of time. Such circumstances shall be communicated to the applicant.

Formal acceptance of preliminary plans shall be made by resolution and constitute approval by the Township of the facilities proposed, dependent upon submission and approval of final plans and specifications for the facilities. Final plans and specifications shall include the Township Engineer's comments.

- b. Application for Review of Final Plans and Specifications

An application in proper form for Review of Final Plans and Specifications in the exact form as shown in Exhibit "C" shall be submitted to the Township Clerk together with the required fees.

Following the presentation or submission of the application to the Township, the Township Engineer shall review the final plans and specifications of the applicant in accordance with the preliminary plans, previously reviewed and approved, Township Engineer comments and the Technical Specifications, included herein.

Final plans shall be complete in all respects, including all required plans and profiles and construction details. Specifications shall be complete in all respects with technical parts to include material and descriptive sections, as outlined in Section IV.

Final plans and specifications shall be based upon approved preliminary plans, previously submitted and approved. In all cases, information or changes requested during the preliminary review shall be included in the final plans. Upon review of final plans and specifications, required local, State and Federal Permit Forms (if any) shall be prepared by the applicant for submittal by the Township. All fees required by these local, State or Federal forms shall be paid by the applicant, at the time of submission by the Township.

The review period for final plans and specifications shall be consistent with the extent of the subdivision or development submitted. In general, this period will not extend beyond sixty (60) days from the date of acceptance for review, unless extenuating circumstances require an extension of time. Such circumstances shall be communicated to the applicant.

The review shall include an evaluation of the design as presented as to conformance to the detailed Rules and Regulations of the Township, the minimum State Standards, and acceptable engineering design practice.

Upon completion of review, the Township Engineer shall make recommendations to the Township for final consideration as to final approval.

2. No changes shall be made to the documents after submission to the Township unless written permission to do so is requested and approved by the Township.
3. After receiving final approval and prior to the start of construction, the applicant shall submit the required inspection fees. In addition, prior to the start of construction, easements shall be conveyed to the Township in a form approved by the Township (See Exhibit "A") as well as a resolution authorizing said conveyance, if applicable.
4. Final approval of plans and specifications by the Township shall constitute authorization to start construction, contingent upon all conditions of approval including other permits and outside agency approvals, and the necessary bonding and fee(s) being received prior to the start of construction.



5. When final approval has been granted by the Township, the applicant shall deliver reproducible drawings of the design to the Township for the appropriate execution; and thereafter deliver four copies of the plans and specifications to the Township for distribution as well as four additional copies to the Township Engineer for use during construction.
6. "Preliminary and Final Approval" will be revoked and void if the applicant has not commenced construction within the time period as specified in the Municipal Land Use Laws (MLUL).

C. DETAILED REQUIREMENTS OF APPLICATIONS

1. General

- a. All applications must be signed by the applicant or a duly authorized agent or representative and include proof of authorization by signed affidavit.
- b. The review period shall, in general, run for a maximum of sixty days from the date of acceptance for review.
- c. The applicant, prior to receiving the reviewed plans, will pay any review fees in excess of the amount posted.

2. Instruction for Applications for Review of Preliminary Plans

Applicant shall file the proper form with the Township Clerk to include the following:

- a. Engineering review fees as stipulated in the Fee Schedule included in the appendix.
- b. Four (4) copies of an overall plan of the proposed subdivision/development on a scale of not less than 1" = 200' with a key map at a scale not less than 1" = 1000'.
- c. Four (4) copies of an overall plan of the proposed sewers, any required pumping facilities and showing all units to be serviced at a scale not less than 1" = 200'.
- d. Four (4) copies of a complete Engineer's Report of the proposed Sanitary Sewer Collection System setting forth the basis of design.

Basis of design for all sanitary sewers shall be in accordance with accepted design practice and existing State standards. All engineering plans, specifications and reports must bear the seal and signature of a professional engineer authorized to practice in the State of New Jersey.

The Engineer's Report shall contain information as to:

a. Sanitary Sewers

1. The extent of the area to be sewerred including the location of the Township sewer proposed to be connected into.
2. The number of connections to be served during the initial and ultimate development, including an estimate of the population.
3. The total daily estimated flow in gallons per day. Estimated flow(s) shall be in accordance with N.J.A.C 7:14A-23.3.
4. The character of the sewage (domestic, commercial or industrial) to be discharged. If industrial, the strength and makeup of the waste must be presented as well as a descriptive narrative of any pretreatment required under Federal, State or County regulations.
5. Analysis of downstream capacity, including all previously approved projects.

3. Instructions for Application for Review of Final Plans

Applicant shall file the proper form with the Township Clerk to include the following:

- a. Four (4) copies of the most recent drawings now under consideration by the Township Planning Board. Final plans shall bear a block for the signatures of approval of the Township as shown on page II-2.
- b. Engineering review fees as stipulated in the Fee Schedule included in the appendix.
- c. Four (4) copies of the plan and profile of all proposed sewers.
- d. Four (4) copies of the construction details for appurtenances such as manholes, siphons, house connections, etc., all in accordance with the standard details for sewer appurtenances included herein.
- e. Four (4) copies of detailed plans for sewage pumping station, and if so required, sewerage treatment plant.

- f. Four (4) copies of the construction specifications for the proposed project including all appurtenances, pumping station and treatment plant.
- g. All application forms required for State and County approvals and permits, filled out in required duplication in the Township's name. Copies of plans, specifications and Engineer's Report required for submittal to the County and State Agencies shall be supplied upon final review and approval by the Township.
- h. All required application fees for review and approval of permits required by State and County Agencies are to be paid by the applicant. Application and review fees shall be included with the final application form to the Township in the form of cash, cashier's check or a certified check in the amount required.

4. Detailed Requirements for Applications

In general, all sewers shall be designed with the parameters set forth in Chapter IV Sewer System Standards.

a. Construction Plans and Profiles

Construction plans shall be similar in scale to those submitted as preliminary plans and shall bear the approval signatures required of final approval. Construction profiles shall be of a horizontal scale of 1" = 50' with a vertical scale of 1" = 5'. Profiles shall show all manholes, siphons, pumping stations, approximate ground elevation, sizes of proposed sewers and design gradients, sewer inverts at manholes based upon U.S. Coast and Geodetic elevation, street and right-of-way identification, as well as stream crossing cover requirements and concrete encasements. All construction plans and profile sheets shall be numbered consecutively and shall contain an appropriate title box and scales. A cover sheet shall be included having a location plan showing the work of a scale not less than 1" = 500' and a sheet index for the plans, profiles and details. All plans shall be of uniform size, 24 x 36 inches with a 1/2-inch border on top, bottom and right side and a 1-1/2 inch border on left side.

b. Construction Drawings - Pumping Station and Treatment Plants (if required)

Construction drawings for pumping stations and treatment plants shall include a site plan of the proposed facility showing property boundaries, natural features such as tree growth, streams, contours, etc., existing and proposed underground piping and utilities, building site orientation and any proposed underground structures.

The detailed plans shall show the arrangement of mechanical and electrical equipment, piping, valves, fittings, etc., both within and outside the structure. Appropriate sections shall be included to adequately identify the work. General architectural schemes as well as the planting scheme for cover trees and shrubs shall be included as well as site improvements. Details required shall include a flow schematic and hydraulic profile for any proposed treatment plant as well as additional details required by the Township Engineer in his preliminary review.

#### Pumping Stations

The following information shall be submitted for all proposed pumping stations and ejector stations. It is preferred that proposed stations be similar in design to those constructed by the Township.

1. Design population and estimated average daily flow.
2. The proposed methods of screening or comminution.
3. The number of pumps to be installed as well as the estimated sizing (minimum two pumps shall be provided, each designed for the peak daily flow for the design year.)
4. The provisions for emergency power or pumping to be provided, as well as information on controls and station climate control.

#### 5. Specifications

Complete specifications for the construction work proposed shall accompany the detailed plans for sewers, pumping stations and treatment facilities. Specifications for sewers shall be as generally outlined in the sample technical specification sections included hereafter and shall include all references to equipment specified as required. Specifications for pumping stations and treatment plants shall include all pertinent data required, including copies of soil borings taken.

#### 6. Cost Estimates

A detailed estimate of the project cost shall be prepared by the Township Engineer that shall include an estimate of the construction costs plus any contingency, the cost of right-of-way or easements, as-built plans, etc. This construction estimate, prepared by the Township Engineer, at his sole discretion, shall be considered the basis for any performance, cash and maintenance bonds required, and all review and inspection fees required, these being dependent upon an estimated construction cost.

7. Certificate of Completion

Following the completion of the work, the applicant shall make application to the Township for a Certificate of Completion in the exact form as Exhibit "D", to include the following:

- a. A statement by the applicant that construction has been satisfactorily completed and that reproducible as-built plans, prepared by the applicant's engineer, have been transmitted to the Township Engineer.
- b. One Digital Copy (on Compact Disc), one reproducible copy, on material acceptable to the Township Engineer and three (3) prints of the as-built plans, marked with the approval of the Township Engineer as follows:

RECORD PLANS

Accepted by Township Water and Sewer Engineer

\_\_\_\_\_  
Date

- c. Such legal documents as are necessary to convey the interests in the facilities to the Township, in the exact form as shown in Exhibit "E".
- d. Affidavit that all contractors, subcontractors, and materials men have been paid in the exact form as shown in Exhibit "F".

8. Performance and Maintenance Guarantees

- a. "Performance Guarantee" and "Maintenance Guarantee" shall mean either cash or third party Surety Bonds from a reputable insurance company in a form that is acceptable to the Township of Barnegat.
- b. Prior to the commencement of any construction of facilities that either will be dedicated to the Township or will remain as private property, the Applicant shall post with the Township a performance guarantee covering said improvements. The amount to be posted under the performance guarantee shall be 120% of the estimated cost of the improvements to be constructed, plus the estimated costs of all inspection fees. The estimated costs shall be prepared by Township Water and Sewer Engineer. The

Township's Solicitor shall approve the form of the performance guarantee before it shall be accepted.

- c. Maintenance guarantee shall be posted upon final acceptance of the improvement for a two (2) year period in an amount of 15% of the estimated cost of the improvements constructed. Final acceptance of the improvements constructed shall not occur until the date that the maintenance guarantee, in a form satisfactory to the Township's Solicitor, shall be received by the Township.
- d. The Applicant shall provide all labor and equipment to facilitate and provide access to all installed facilities during the Township Water and Sewer Engineer's final inspection of the facilities for the purposes of release of both Performance and Maintenance Guarantees.

III. SEWER SYSTEM STANDARDS FOR  
CONNECTIONS OTHER THAN DEVELOPMENTS –  
INDIVIDUAL CONNECTIONS

### III. SEWER SYSTEM STANDARDS FOR CONNECTIONS OTHER THAN DEVELOPMENTS - INDIVIDUAL CONNECTIONS

#### A. RESIDENTIAL CONNECTIONS

Property owners of residential lots, who are required to connect to an existing sanitary sewer of the Township, shall file an application for sewer connect with the Township Clerk together with the required inspection and connection fees as set forth in the user rates adopted by the Township.

Sewer connections shall be made to an existing sewer of the Township only under the supervision and inspection of a Township representative. Connections will only be allowed using an approved saddle (Inserta-Tee) or existing "tee" or "Y". All connections shall be made according to the standard details included hereafter.

#### B. COMMERCIAL AND INDUSTRIAL CONNECTION

Commercial and industrial units shall file an application with the Township together with the required information and fees as outlined hereafter.

Each separate and independent commercial unit shall be provided with an individual and separate sewer service connection.

The Township may require additional review as prescribed for developments and subdivision, dependent upon the extent of the commercial or industrial complex proposed. Commercial units, consisting of estimated flows similar to residential connections, will be handled according to those rules and regulations prescribed for residential connections, hereafter noted. (Will provide facilities in accordance with regulations applicable to residential connections.)

Larger commercial units and all proposed industrial units must file application forms as detailed under the development and subdivision section (Section III B).

Connections of larger commercial units and all proposed industrial units shall be made only to manholes of the Township. If a Township manhole does not abut the property, the Township shall determine whether an extension to an existing Township sewer is economically feasible. No direct connections will be permitted to the OCUA interceptor system. In cases where an OCUA interceptor abuts the applicant's property, the applicant will be required to install a manhole prior to connection to the OCUA system. The manhole pipe between the manhole and OCUA manhole and access easements will be given at no cost to the Township.

Where shops, stores or buildings are leased or rented, the Owner of the property shall be responsible for informing the Township of any change in the nature of the wastewater to be discharged into the sewer system caused by change of tenants or nature of use of such rented property.



C. REQUIREMENTS - INDIVIDUAL HOUSE CONNECTIONS

1. No unauthorized person shall uncover, make any connections with or opening into, use, alter, or disturb any Township sewer or appurtenance thereof without first obtaining written authorization from the Township.
2. All costs and expenses required for the installation and connection of a house connection or building sewer shall be borne by the owner. The owner shall be liable to the Township for any loss or damage that may directly or indirectly be occasioned by the installation of any house connection or building sewer, or any other cause.
3. Each separate and independent residential and commercial unit shall be provided with an individual and separate house connection or building sewer.
4. In all cases, the house connection or building sewer shall be installed at an elevation below grade sufficient for frost protection. Because of economics, the Township is not obligated to serve basement fixtures. The Township Engineer for unusual circumstances will consider exceptions submitted in writing at the time of application. The applicant will be responsible for any additional cost incurred by the Township. The Township will not assume responsibility for any fixture that is lower than eight (8) inches above the nearest manhole in the street.
5. No person shall make connection of roof downspouts, exterior foundation drains, or other sources of surface runoff, groundwater, uncontaminated cooling water or unpolluted industrial process waters to a house connection or building sewer which is in turn connected directly or indirectly to a Township sewer.
6. The installation of a house connection or building sewer to the Township sewer shall conform to the requirements of the building and plumbing codes of the Township. All such connections shall, in general, be gas tight and watertight. No deviation from the prescribed procedures and materials will be allowed unless prior approval is obtained from the Township.
7. All excavations for house connection or building sewer installations shall be adequately guarded with barricades and lights so as to protect the public from hazard. Streets, sidewalks, curbs, parkways and other public properties disturbed during the course of the work shall be restored in a manner satisfactory to the Township and the Township Water and Sewer Engineer.
8. No person shall perform any of the work set forth in these rules and regulations for any other person in the Township, unless he shall be

licensed plumber or utility contractor authorized to perform work in the Township.

9. The joint made between the sewer branch connection and the house connection or building sewer provided by the owner shall be secure and watertight. Standard approved PVC fittings with flexible joints shall be used for the connection.
10. A riser and cleanout shall be installed on the sewer branch connection, in accordance with the standard details, at a point two feet on the house side of the curblineline. This riser and cleanout shall be considered the end of the Township's jurisdiction. Beyond this point, the sewer line to the building is considered a building sewer under the responsibility of the property owner.
11. Connection Fees and Equivalent Dwelling Units shall be calculated in accordance with the Schedule of Equivalent Dwelling Units and the Fee Schedule.

D. PROCEDURE - INDIVIDUAL HOUSE CONNECTIONS

1. The owner or licensed plumber or sewer contractor must obtain, and file with the Township an "Application for Sewer Connection" in the exact form as Exhibit "H". The application, together with the required connection fee as set forth in the Fee Schedule adopted by the Township, shall be submitted to the Clerk's Office. Four (4) copies of the application shall be submitted to the Township together with the required connection fee in cash, cashier's check or certified check made payable to Barnegat Township.
2. The connection fee does not include the costs of any work or cost for obtaining a road opening permit or any required performance guarantee(s), which may be required by the Township. All costs associated with the work and all road opening permits are the responsibility of the applicant.
3. The application shall be completed in all respects, excepting the permit number and inspection dates, and shall include a sketch, in the appropriate area of the application form, showing the connection location, with sufficient dimensions to indicate compliance with the rules and regulations and to permit future location of the service. For all new construction, a plot plan showing the location and method of connection should be submitted with the application.
4. The Township shall review the application as to completeness and compliance and, upon approval, authorize the issuing of a "Permit for Installing of Sewers". This permit must be posted in clear view, at the site of the connection during the entire period of construction.

5. All road opening permits must be obtained by the applicant.
6. Upon completion of all pipe work and prior to backfilling and connection to the lateral, the applicant shall request the Township to inspect the completed work. The applicant shall notify the Township and the code enforcement official a minimum of two working days prior to the date upon which he would anticipate the work to be inspected.
7. After inspection and approval of the installation by the Township and code enforcement official, the applicant shall complete the connection to the building unit and backfill the trench with tamped material to the surface.
8. The owner is responsible for maintaining the house connection or building sewer in a safe and watertight condition from the building to the curb line or easement line.

E. MATERIALS – INDIVIDUAL HOUSE CONNECTION

The house connection, building sewer or lateral shall be PVC SDR 35 pipe, conforming to the specification of the Plastics Pipe Institute and ASTM D3034. Alternate material, when there is insufficient cover, shall be ductile iron pipe conforming to ANSI A21.51.

Pipe shall be bedded on a tamped granular material. All house connections or building sewers shall be installed in a separate trench from any existing or proposed water line, separated by at least 10 feet. The house connection shall have a minimum nominal inside diameter of 4 inches and shall be laid on a slope of not less than 1/4 inch per foot, unless permission for change is obtained from the code enforcement official. Pipe shall be laid as straight as possible with cleanouts set at angle points greater than 45 degrees and at fifty foot intervals where the house connection is over seventy five feet long, all in accordance with Plumbing Code.

F. REQUIREMENTS - LARGE COMMERCIAL AND INDUSTRIAL UNITS

1. No large commercial or industrial unit shall make any connection into, use, alter, or disturb any Township sewer main or appurtenance thereof without first obtaining a written authorization from the Township. Application for authorization shall be on forms provided and shall be applied for in accordance with rules and regulations for subdivisions and developments as found in the appropriate section.
2. All costs and expenses required for the installation and connection of a large commercial or industrial building sewer service connection shall be borne by the applicant. The owner shall be liable to the Township for any loss or damage that may directly or indirectly be occasioned by the installation of any sewer service connection or any other cause.

3. The connection of a building sewer for a large commercial or industrial unit shall be to an existing manhole of the Township system. In special cases (i.e. chemical, process, heavy grease producing facilities, restaurants, etc.), grease traps and/or metering and sampling may be required for all flow prior to its acceptance into the Township system. The cost of all metering and sampling facilities required, if so determined at the sole discretion of the Township Engineer, shall be borne by the owner.
4. The Township shall monitor industrial pretreatment. Failure to comply with industrial pretreatment requirements may require that the Township disconnect or plug the building sewer from the Township system.
5. Requirements for inspection by the Township, as listed under Section D - "Procedures - Individual House Connections" shall also apply to large commercial and industrial unit connections.
6. Connection Fees and Equivalent Dwelling Units shall be calculated in accordance with the Schedule of Equivalent Dwelling Units and the Fee Schedule.
7. Estimated sanitary sewer flow shall be determined by reference to the NJDEP Regulations "Projected Flow Criteria", NJAC 7:14A – 23.3.

G. PROCEDURES - LARGE COMMERCIAL AND INDUSTRIAL UNITS

1. Exhibit B - Application for Review of Preliminary Plans
  - a. The owner must obtain, complete and file in proper form with the Township, an "Application for Review of Preliminary Plans" in the exact form as Exhibit B together with the required fees.
  - b. Following presentation or submission of the application to the Township, the Township Water and Sewer Engineer shall review the proposed commercial or industrial unit to determine the extent of sanitary facilities to be required.

The review by the Township Water and Sewer Engineer will determine the following information:

- a. The extent of the facilities to be required.
- b. The extent of pretreatment required, dependent upon the strength of the initial industrial waste and its deleterious effects on the Township system.

Applicants shall include a detailed estimate of the sewer demand and/or daily water consumption of the development and from this determine the

number of units involved. The nature of the wastewater to be discharged into the sewer system shall also be included. The Township at its sole discretion will determine whether the applicant will be required to install a grease trap and/or wastewater metering/sampling pit at the point prior to discharge into the sewer system.

The review period for preliminary plans shall be consistent with the extent of the commercial or industrial unit proposed. In general, this period will not extend beyond sixty (60) days from the date of acceptance for review unless extenuating circumstances require an extension of time. Such circumstances shall be communicated to the applicant.

Acceptance of preliminary plans shall be made by resolution and constitute approval of the Township of the facilities proposed, dependent upon submission and approval of final plans and specifications for the facilities. Final plans and specifications shall include the Township Engineer's comments.

2. Exhibit C - Application for Review of Final Plans and Specifications

- a. The owner must obtain, fill out in proper form and file with the Township Clerk an "Application for Review of Final Plans and Specifications in the exact form as Exhibit C together with the required fees.
- b. Following presentation or submission of the application for review by the Township, the Township Engineer shall review the final plans and specifications of the applicant in accordance with the preliminary plans, previously reviewed and approved Township Engineer's comments and the technical specifications.
- c. Final plans shall be complete in all respects, including all required plans, profiles and construction details.
- d. Specifications shall be complete in all respects with technical parts to include material and descriptive sections.
- e. In all cases, information or changes requested by the Township under the preliminary review shall be included under the final plans.
- f. All required permits, whether County, State or Federal shall be secured by the applicant prior to the start of any construction. No tie-in to any Township sewer main will be allowed or approved until all permits are secured and all conditions of approval have been met.

- g. The review period for final plans and specifications shall be as required by the extent of the commercial or industrial unit proposed. In general, this period will not extend past sixty (60) days from the date of acceptance unless extenuating circumstances require an extension of time. Such circumstances shall be communicated to the applicant.
- h. The review shall include a check of the plans and specifications, by the Township Engineer as to conformance to the rules and regulations of the Township, minimum State standards and accepted engineering design practices.
- i. Upon completion of review, the Township Engineer shall make his recommendations to the Township as to final approval.
- j. Notification of final acceptance of plans and specifications shall constitute authorization to commence construction, assuming all permits and approvals are received prior to the anticipated date for the start of construction.
- k. "Preliminary and Final Approval" will be revoked and void if the applicant has not commenced construction within the time period as specified in the Municipal Land Use Laws (MLUL).

H. MATERIALS – LARGE COMMERCIAL AND INDUSTRIAL UNITS

All building sewers shall be PVC pipe or ductile iron, if there is less than 4 foot of cover, as specified herein in the Technical Specification section. Pipe shall be bedded on tamped granular material and shall be laid straight between manholes. Other related requirements as listed in the Technical Specifications shall be included in the Project Specifications and adhered to during construction.

## IV. DETAILED SPECIFICATIONS FOR SANITARY SEWER CONSTRUCTION

IV. DETAILED GENERAL SPECIFICATIONS FOR SANITARY SEWER CONSTRUCTION

A. INTRODUCTION AND PURPOSE

These specifications are to be considered the minimum acceptable standards for Sanitary Sewer Systems in developments, subdivisions and industrial and commercial projects lying within the Township or connecting to the collecting system of the Township, including the connections from main sewers to the point of connection with the building outlet. Typical drawings are included hereafter to illustrate requirements and complement the specifications.

B. GENERAL REQUIREMENTS

The sewer system flow shall be one directional, with no loops. Sewers shall be sloped in accordance with the minimum requirements of the State.

All lots within a subdivision shall be sewerred and adjacent properties shall be taken into consideration when review of plans is initiated by the Township.

C. PERMITS AND FEES

The applicant shall secure all permits, licenses and bonds, and shall pay all fees required in the prosecution of the work.

NOTE: IN ALL SECTIONS OF THE FOLLOWING SPECIFICATIONS THE REFERENCE TO "ENGINEER" SHALL MEAN BOTH THE TOWNSHIP WATER AND SEWER ENGINEER AND THE ENGINEER FOR THE OWNER.



D. STANDARD TECHNICAL SPECIFICATION FOR CONSTRUCTION OF SANITARY SEWERS

1. GENERAL INFORMATION

1.00 QUALITY OF MATERIALS AND WORKMANSHIP

The attention of contractors is directed to the requirements of the specification intended to assure safe, watertight and otherwise adequate structures. The contractor shall realize fully that first-class materials and workmanship specified must be supplied in full measure to produce acceptable structures and equipment, which will give uninterrupted service for an extended period.

1.01 SEQUENCE OF CONSTRUCTION OPERATIONS AND TIME SCHEDULE

Prior to construction the contractor shall submit a construction schedule to the engineer for approval. The schedule shall include sequence of construction activity and estimated time of initiation and completion of each phase of the work.

1.02 LINES AND GRADES

The intent of this paragraph is to outline procedures for the contractor to transfer grade stake information to the construction site. The use of batter boards is optional. The contractor may use laser or whatever other procedures he deems sufficient to construct sewers and other appurtenances to the proper line and grade.

Attention of contractor is directed to the following specific requirements regarding the establishing and transferring of lines and grades:

- A. The contractor will establish all benchmarks and the position of control points on the site of the work. From these established controls the contractor shall run all offset lines, set and drive stakes, set batter boards, and take all other measurements in order to lay out the work in accordance with the intent of the contract drawings. After the contractor has erected batter boards, or forms, and set elevations for the structures, the engineer will check such work for alignment, grade and location of steel, piping and equipment. Only upon approval of the engineer shall the contractor proceed with permanent construction of the work so checked.
- B. The contractor shall set points to control line and grade of all pipelines. Points shall be set at a minimum fifty (50) foot stationing and at all manholes and changes of line and grade.
- C. Contractor shall verify grades as work progresses. When requested by the engineer, the contractor shall assist the engineer in any manner that may be necessary to verify the grades and alignment as well as other features of the work. No claim will be made for the services.

Failure to comply with this provision shall be sufficient cause for the Township to stop the work on unchecked sections.

- D. The contractor shall adequately protect all monuments, stakes and benchmarks checked by the engineer. If the contractor during the progress of the work disturbs them, they will be replaced at the contractor's expense.

1.03 LEAKAGE

The attention of the contractor is called to the specific requirements of this contract whereby the most rigid supervision will be required to insure an absolute minimum of leakage or infiltration.

1.04 CLEAN-UP

During the course of construction all efforts shall be made to maintain a neat and orderly project. Clean up shall be pursued on a regular basis and in conjunction with the construction.

Upon completion of all construction, final clean up shall include removal of all excess material, equipment, backfill, etc., and the site shall be restored to a condition equal to or better than that existing prior to construction.

1.05 CERTIFICATE OF INSURANCE

Certificates of liability and workmen's compensation insurance satisfactory to the Township and the engineer shall be filed with the Township and the engineer prior to the start of construction. All of the contractor's insurance coverage shall contain a clause indemnifying and saving harmless the Township and the engineer and their agents from any and all liability of whatever nature arising from the work to be performed under the contract, including attorney's fees and costs in connection with the defense of such claims. The certificate of insurance furnished by the contractor shall state specifically that the above indemnification is guaranteed by the policy, and shall be as shown hereafter.

The minimum amounts of insurance to be carried by the contractor shall be as follows:

A. WORKMEN'S COMPENSATION AND EMPLOYER'S LIABILITY INSURANCE

The contractor shall take out and maintain during the life of this contract, adequate workmen's compensation and employer's liability insurance for all employees employed in connection with the work, and in case any work is sublet, the contractor shall require each subcontractor similarly to provide workmen's compensation and employer's liability insurance for the latter's employees, unless such employees are covered by the protection afforded

by the contract. Employer's liability insurance shall have limits of not less than \$500,000 per accident, or for disease \$100,000 per claim.

B. Public personal injury liability and property damage liability, including contingent liability and contractual liability:

One person in any one occurrence	\$ 500,000
Two or more persons in any one occurrence	1,000,000
Property damage in any accident	500,000
Aggregate property damage limit	1,000,000

C. Automobile liability insurance:

One person in any one occurrence	\$ 500,000
Two or more persons in any one accident	1,000,000
Property damage in any one accident	500,000

Property damage insurance shall be extended to cover damage to underground wires, pipes, ducts, conduits, structures, etc., and further to cover explosion damage and damage due to collapse.

A certificate endorsed by the insurance company shall be furnished, stating that said company will notify the Township ten days in advance of any cancellation becoming effective.

The policies shall remain in force until all work has been completed.

The following clause shall be included on all insurance forms:

"The contractor agrees to assume the defense of and indemnify and save harmless the Township and the consulting engineer of the Township and their employees, officers and agents from all claims related to labor or materials, furnished for the work or in doing the work; to injuries to any person or corporation received or sustained by an act of the contractor or his employees in doing the work, or in consequence of any improper materials, implements or labor used therein; and to act, omission or neglect of the contractor and his employees therein."

1.06 DEWATERING FACILITIES

The contractor shall provide, to the satisfaction of the Township Engineer, suitable and adequate dewatering equipment to insure satisfactory construction and maximum progress. Where groundwater is encountered the groundwater must be kept to a level 2 ft. below the bottom of the trench during the laying of pipe.

1.07 MARKERS FOR BRANCH CONNECTIONS ON SEWERS

No branch connection shall be backfilled until accurately located by the engineer. At the terminus of all sewer branch connections, the contractor shall place a 4-foot length of 2 x 4 with the top at prevailing grade. The 2 x 4 is not required if a cleanout has been installed.

Where tees are installed in sewers for future house connections, the location shall be marked with a similar marker with the top 2 inches below pavement.

1.08 MAINTAIN STREETS DURING AND SUBSEQUENT TO CONSTRUCTION

Unless specifically permitted, not more than 100 feet of trench shall be left open by any single work force.

Final clean up, including removal of excess pipe, backfill, or other material, shall be carried along the pipe laying, and in no case shall the clean up lag behind the forward terminus of pipe laying by more than 200 feet.

In congested areas, or where necessary to minimize interference with traffic or access to business properties, private garages and homes, or in the interest of fire protection, backfill shall be completed within 10 feet of forward pipe laying, on the same day.

1.09 NEW DEVELOPMENTS

The strict requirements of the above paragraphs applying to maintenance, traffic, excess material, etc. shall apply to existing public streets. Where the contractor is installing sanitary facilities in a new development where streets are not yet constructed and homes are not occupied, these requirements may be modified to the extent that they may conflict with contractual arrangements between the owner and the contractor.

2. GENERAL SPECIFICATIONS

2.00 EQUIVALENT MATERIALS AND EQUIPMENT

Where in the following specifications a material, article, manufacturer, or distributor is specifically named, it is done only for the purpose of clearly defining the kind and quality of the material or article desired. It is to be understood that the determination of equivalency will be at the sole discretion of the Township Engineer.

2.01 MATERIALS AND WORKMANSHIP

All materials, fixtures, fittings and supplies furnished shall be of standard first grade quality and of the best workmanship and design. Where the characteristics of any materials are not particularly specified, approval shall be granted of those

materials used customarily in first-class work of the nature for which the material is general employed. All work of assembly and construction must be done in a neat, first-class and competently executed manner.

Any required physical tests of materials will be made by the contractor, unless otherwise specified. The contractor shall furnish test.

Pieces and samples in the number, shape, size and finish required. Tests will be made in accordance with the standard methods adopted by the American Society for Testing Materials for the materials involved.

## 2.02 EQUIPMENT

Contractors shall, and must familiarize themselves thoroughly with the type and nature of the equipment required in the proper execution of the work, and shall use and employ only first-class equipment. Previously used equipment must be in safe and in first-class working order and condition. Sufficient equipment must and shall be furnished and used to permit the completion of the work within the time specified. The equipment used on any portion of the work shall be such that no injury or damage to the roadway, adjacent property, or other thoroughfare or highway will result from its use.

## 2.03 CONSTRUCTION SCHEDULE

Within ten days prior to the start of the work, the contractor shall file a construction schedule with the engineer. The schedule, in the form of a progress chart, shall set forth, in detail, the procedure to be followed in the execution of the work. The schedule shall indicate the dates of commencement and completion of the several operations and portions of the work. Upon acceptance by the engineer, the schedule shall be made the basis of operations. If at any time, in the opinion of the engineer, the scheduled progress is not being maintained, amendments shall be made to the Construction Schedule of Operations, and correspondingly to the contractors equipment and work force, to maintain the progress of the work. Such changes shall be subject to the acceptance of the engineer, but such action by the engineer or the failure so to act shall not relieve the contractor of any responsibility under this contract.

## 2.04 SHOP OR SETTING DRAWINGS

The contractor shall submit for the review of the engineer, shop drawings for all prefabricated work and for all manufactured items required to be furnished in the contract as required by the specifications.

When submitted for the engineer's review, shop drawings shall bear the contractor's certification that he has reviewed, checked and approved the shop drawings and that they are in conformance with the requirements of the contract documents. By approving and submitting shop drawings, the contractor represents that he has determined and verified all field measurements and quantities, field construction

criteria, materials, catalog numbers and similar data, and that he has reviewed and coordinated the information in the shop drawings with the requirements of the work.

Engineer's review of the contractor's shop drawings shall be considered as a service given as assistance to the contractor in interpreting the requirements of the contract and in no way shall it relieve the contractor of any of his responsibilities. Any fabrication, erection, setting or other work done in advance of the receipt of shop drawings returned by the engineer and noted as "No Exception Taken" shall be entirely at the contractor's risk.

The Engineer's review will be confined to general arrangement and compliance with the contract plans and specifications only and will not be for the purpose of checking dimensions, weights, clearances, fittings, tolerances, interference or coordination of trades. Shop drawings submitted by subcontractors shall be sent direct to the contractor for approval. The contractor shall be responsible for their submission to the engineer. The contractor shall thoroughly check all subcontractors' shop drawings as regards measurements, sizes of members, materials and details to satisfy him that they conform to the contract plans and specifications. Drawings found to be inaccurate or otherwise in error shall be returned to the subcontractor by the contractor for correction before submitting them to the engineer. All details on shop drawings submitted for review shall clearly show the relation of the various parts and where the work depends upon field measurements, such measurements shall be obtained by the contractor and noted on shop drawings before being submitted for review.

Sufficient space on the shop drawings near the title box should be provided for stamps and review comments. The shop drawings shall bear the initials of the detailer's checker prior to submission. The contractor or his detailer shall do all dimensional coordination.

All submissions shall be properly referenced to indicate clearly the specification section, location, service and function of each particular item. All submissions for one item or group of related items shall be complete. Where manufacturer's publications in the form of catalogs, pamphlets or other data sheets are submitted in lieu of prepared shop drawings, such submissions shall specifically indicate the item for which review is requested. Identification of items shall be made in ink and submissions showing only general information are not acceptable.

If the shop drawings contain any departures from the contract requirements, specific mention thereof shall be made in the contractor's letter of transmittal. Where such departures require revisions to layouts or structural changes to the work as shown, the contractor shall, at his own expense, prepare and submit revised layout drawings for review. Revision drawings shall include design calculations prepared by a professional engineer. Such drawings shall be the same size as the contract drawings unless specified otherwise. The contractor shall coordinate all reviewed equipment shop drawings with shop drawings of related new and altered

structures, supports, piping, electrical and mechanical work to insure proper accommodation of the furnished equipment. Shop drawings for structures, supports, piping, electrical and mechanical work, which are contingent upon the specific equipment furnished, shall not be submitted until the equipment shop drawings have received final acceptance,

No work shall be done upon any part of a structure until the engineer conducts the necessary review. Six (6) sets of all shop or working drawings shall be submitted, unless otherwise specified, to the engineer through the contractor. If requested by the contractor and acceptable to the engineer, initial shop drawings submitted by the contractor may consist of two (2) copies and a sepia. Only drawings that have been checked and corrected by the material fabricator should be submitted. The contractor shall be responsible for the prompt submission of all shop or working drawings, so that there shall be no delay to the work due to the absence of such drawings. Shop drawings shall be either 8 1/2 x 11 inches or 24 x 36 inches.

Four (4) copies of reviewed shop drawings will be returned to the contractor.

Before final acceptance is made the contractor shall deliver to the engineer two (2) complete bound sets of final accepted shop drawings applicable to the contract for the Township's permanent file. Reproducibles (8 1/2 x 11 or 24 x 36) may be required by the engineer.

#### 2.05 SANITARY FACILITIES

Sanitary facilities, properly screened from public observation, for the use of all persons employed on the work and beginning with the first workers engaged in preliminary operations, shall be provided prior to the start of construction and maintained by the contractor in sufficient numbers, in such manner and at such locations as shall be approved. Sanitary facilities shall be completely self-contained and chemically treated.

#### 2.06 CLEANING UP

Before completion of the work, the contractor shall tear down and remove all temporary structures unless expressly directed otherwise, and shall remove rubbish of all kinds from all contract structures and from the site occupied during the progress of the work. The contractor shall remove all concrete and ballast droppings and shall leave the site and the adjacent property, which may have been affected by his operations in a neat and satisfactory condition. All structures and parts thereof constructed by the contractor shall be thoroughly cleaned and left in first class condition.

#### 2.07 EXPLOSIVES

Explosives, if required, shall not be brought onto the job site without prior written acceptance of the engineer. Explosives shall be stored safely under lock and key. The storage places shall be marked conspicuously "Dangerous explosives" and be

in care of a competent watchman at all times. The storing and handling of explosives and highly inflammable materials shall conform to the state and local regulations relating thereto. Proper means shall be used to avoid damage by blasting to public and private property, and flagmen shall be provided when necessary to warn any persons and passing traffic.

2.08 SPECIAL REQUIREMENTS IN AND ADJACENT TO COUNTY ROADS

The attention of the contractor is specifically directed to the requirements of the Ocean County Road Department when working adjacent to county roads. Trench backfill and compaction shall be as specified elsewhere. The adjacent pavement shall be maintained in a broom-swept clean condition and all work shall be so cleaned up at the close of operations each day. No trench shall be left open at night without the written approval of the Engineer. Access to all property, including driveways along the roads shall be maintained at all times.

2.09 OPEN EXCAVATION, SAFETY BARRICADES, WATCHMAN

The attention of the contractor is specifically directed to the requirements in connection with the protection of all excavations and the safety of all persons. Due to the character of the work, excavations for pipe and structures will, in places, be wide and deep and the contractor shall be expected to keep all excavations protected at all times. He shall use suitable and adequate barricades around all openings and shall provide lights at night; warning signs shall be located, where required, including "Soft Trench" signs.

No trench shall be left open at night without the written approval of the Engineer.

Barricades shall be adequately braced. The use of intermittent plank barriers carried on "Horses" will not be permitted in locations that are hazardous. Backfilling to the surface will be required as soon as practicable.

If required by the Township, the contractor shall provide personnel for the sole purpose of insuring the safety of persons other than his own employees, by directing traffic, issuing warnings, resetting barricades, etc. If deemed necessary by the Township the contractor shall be required to have a watchman present at night in particularly hazardous locations.

Regardless of the provisions of this section it shall be the contractor's sole responsibility for the safety of his employees and the public.

2.10 TREE PROTECTION AND TREE REMOVAL

It is intended to protect and save trees from removal wherever possible particularly through rights-of-way and along street shoulders. Where methods of construction or minor relocation will avoid tree removal, such methods will be employed without additional compensation. Trees outside of the right-of-way line shall in no case be disturbed and boxing shall be provided as may be required to protect trees



adjacent to the right-of-way lines. Tree roots shall be tunneled under or folded back but shall not be cut.

2.11 TRENCH CONSOLIDATION, BACKFILL, CLEAN-UP AND TRAFFIC MAINTENANCE

Trench backfill shall be prosecuted expeditiously upon completion of pipe laying. Backfill and compaction shall commence in uniform lifts not exceeding 12” in thickness.

All excess trench excavation shall be removed from the site daily and each street backfilled shall be broom-swept to afford a clean pavement surface. The contractor shall maintain those streets in a clean condition and shall make daily inspections with the engineer to examine all trenches. Where settlement occurs, the trench shall be repaired immediately to bring the trench up to grade.

Soft trench signs, lights, and barricades shall be maintained over all trenches until pavement replacement is made. The contractor shall arrange for traffic rerouting, detours, and barricade placement in consultation with the police, engineer or inspector.

2.12 PAVEMENT REPLACEMENT

Pavement replacement over trenches shall be made as soon as possible after trench consolidation. Installation and placement shall be in accordance with township, county or state standards. A temporary pavement section may be required until such time has elapsed for compaction prior to final paving.

2.13 CONTROL AND PROTECTION OF TRAFFIC AT CONSTRUCTION SITES

Vehicular and pedestrian traffic on roadways shall be maintained and protected at all times and all operations in or adjacent to roadways, sidewalks, and walkways shall be conducted and controlled accordingly.

The contractor, shall, for the protection of the traveling public and his personnel, familiarize himself and adhere strictly to the requirements of these specifications and to the requirements of the Motor Vehicle Code of the State of New Jersey, wherever it shall pertain to necessary and required precautionary measures regarding the type of work being done.

Traffic on all roadways within the contract area is under the direct supervision and control of the Police Department of the Township of Barnegat hereinafter referred to as the police, who will enforce these requirements and the Motor Vehicle Code as they pertain to the contractor.

If the police notify the contractor of any hazardous construction practice, violation of the regulations, or violation of the Motor Vehicle Code, or if traffic volumes

become excessive, all operations shall be discontinued and immediate remedial action shall be taken to the satisfaction of police before work is resumed.

The safety measures outlined herein shall be considered as minimum standards. The final responsibility for the installation of adequate safety precautions and for the protection of the traveling public and his own personnel shall rest with the contractor.

Compliance with all prescribed safety precautions contained herein shall not relieve the contractor of his primary responsibility to take all necessary measures to protect and safeguard the work, nor relieve him of any responsibilities.

Furthermore, the contractor shall, where it may be necessary for emergency repairs or service at the site of the work under construction, register at Police Headquarters the names and telephone numbers of responsible representatives of the contractor who may be contacted to correct any hazardous conditions which may arise at times other than the normal working hours.

During non-working hours, roadway lanes, sidewalks, walkways and shoulder shall be kept free of obstructions, including construction vehicles, whenever they may present a hazard to passing traffic. In the event an obstruction cannot be removed it shall be the responsibility of the contractor to so mark the obstruction as to eliminate any hazard to vehicular traffic and, to provide a safe passage area for pedestrians.

Whenever the contractor will be performing an operation which requires the closing of a lane of traffic, even for brief periods of times, the contractor shall close the lane and so mark it with the necessary protective devices in accordance with the requirements hereinafter set forth.

#### 2.14 NOTIFICATION OF UTILITY COMPANIES

Prior to the start of any work in the vicinity of existing utilities or other subsurface facilities, the contractor shall notify the utility company at least three days in advance of the start of his work. The engineer shall be furnished, in writing, the time at which such notice was given and the name and position of the person contacted. (Call 811 for Garden State Underground Location)

### 3. TECHNICAL SPECIFICATIONS - SANITARY SEWERS & FORCE MAINS

#### 3.00 EXCAVATION

Excavation shall be of sufficient width to permit work to be done safely and competently. In no cases shall excavations be carried below grade and backfill be used to bring foundations to the grade of bottom slabs, footings or pipelines.

In all excavations for pipe, boulders, rock, masonry or other similar materials shall be excavated to a level at least six inches below the invert of the pipe, and carefully

refilled with bedding material clean 3/8" broken stone. Rock or boulders shall be removed from sides of trenches to a plane 12" outside the inside wall of the pipe unless written permission to do otherwise is expressly given. Bedding material shall be extended up to 12" above the proposed top of pipe.

The trench width just above the top of the pipe shall be maintained as narrow as possible and shall not exceed that shown on the standard details.

3.01 UNAUTHORIZED EXCAVATION

If any excavation is caused by the contractor's error, or wherever the excavation is carried beyond or below the lines and grades, the contractor shall, at his own expense, refill all such excavated spaced with such material and in such manner as may be directed in order to insure the stability of the various structures.

3.02 SHEETING AND BRACING

Where necessary, particularly to prevent disturbance, damage or settlement of adjacent structures, pipelines, utilities, improvements or paving, excavation shall be adequately sheeted and braced. Sheeting and bracing of all excavation shall comply with the latest requirements of OSHA.

Any damage to new or existing structures occurring through settlement, water or earth pressure, or other causes due to inadequate bracing, or through negligence or fault of the contractor in any other manner, shall be repaired by the contractor at his own expense.

3.03 DRAINAGE AND DEWATERING

The contractor shall control grading in a manner to prevent water running into excavations. Obstruction of surface drainage will not be permitted and a means shall be provided whereby storm water can flow uninterrupted in existing gutters, other surface drains or temporary drains. Material for backfill or for protection of excavation in public roads from surface drainage shall be neatly placed and kept shaped so as to cause the least possible interference with public travel. Free access must be provided to all fire hydrants, water gate valves, meters, and private drives.

Dewatering shall be accomplished by methods that shall insure that the ground water will be drawn down to an elevation two (2) feet below the bottom of the bedding. Upon removal of well points, deep wells, or other dewatering equipment, the contractor shall backfill, compact, and pave (in roads) all holes. Well point and deep well holes shall be compacted for the full depth to a density equal to in situ soils.

Dewatering for the structures and pipelines shall commence when ground water is first encountered and shall be continued until such time as the backfill operation has been completed. The engineer may direct the contractor to continue dewatering operations for an additional two (2) days after backfilling has been completed. No

concrete footings or floors shall be laid in water nor shall water be allowed to rise over them until the concrete or mortar has set at least eight (8) hours. Water shall not be allowed to rise unequally against walls for a period of 28 days. Groundwater shall not be allowed to rise around the pipe until the trench is backfilled.

3.04 TOPSOIL

In unpaved areas all topsoil shall be carefully removed from the site of the work over the entire width of the contractor's operations, including areas used for stockpiling excavated material and over which equipment will be driven. Topsoil shall be stored separately and replaced in the final grading and embankments to the designated lines and grades.

3.05 BACKFILL & SUITABLE BACKFILL

As construction of the pipe and appurtenant structures progresses, previously excavated materials, where deemed satisfactory by the engineer, may be reused as backfill.

Where, in the opinion of the engineer, excavated material is unsuitable, it shall be removed from the site and not reused in the excavated trenches or around structures. Backfill materials to be used when the previously excavated material is considered unsuitable by the engineer is defined as follows:

"Suitable Backfill" shall be used where the material previously excavated is not deemed suitable for backfill by the engineer, and shall be used within the limits indicated on the drawings. "Suitable backfill" shall be either previously excavated excess material which has been stockpiled and is free from refuse, broken road pavement, moist stiff clay, organic material or other materials considered deleterious by the engineer or bank-run sand. "Suitable backfill" shall not have fines in excess of ten percent passing a 200 sieve or have coarse gravel larger than 1½".

3.06 TRENCH WIDTHS

Trench widths (see drawings) for gravity sewers and stubs shall be as follows:

Polyvinyl Chloride Pipe

Stable Bedding – Outside diameter of pipe plus two feet

Unstable Trench – Five times the pipe inside diameter centered over the pipe

Ductile Iron Pipe – Outside diameter of pipe plus two feet

### 3.07 BURIED UTILITIES AND STRUCTURES

The contractor shall accurately locate all utilities, structures and appurtenances in the field. The contractor shall also make ail arrangements and liaisons with the utility companies concerned to mark their lines, structures and appurtenances by coded symbols on the pavement or marked stakes. All of the above shall be done well in advance of any construction

### 3.08 OVER EXCAVATION

#### DEPTH

Where the contractor, inadvertently over-excavates below the pipe bedding or structure crushed stone foundation course, he shall be required, in order to reestablish adequate soil bearing capacity, to conform to the following requirements:

#### A. Polyvinyl Chloride

Overdepth excavation from 6" to 12" below the bottom of the pipe shall be rectified by backfilling with proper bedding material 3/8" clean stone.

#### B. Ductile Iron Pipe

Overdepth excavation shall be rectified by backfilling with number 57 coarse aggregate, compacted to provide a firm and unyielding subgrade.

#### C. Structures

Overdepth excavation below the 12" crushed stone (choked) foundation course for the structure shall be rectified by backfilling with additional crushed stone (choked). The crushed stone (choked) shall be placed from the bottom of the over excavation to the bottom of the structure.

#### WIDTH

Where the contractor inadvertently over-excavates to a greater width than the pipe trench width limits (within the bedding area) he shall be required to conform to the following requirements:

#### A. Polyvinyl Chloride

For the stable bedding foundation (O.D. +2') the contractor shall be required to excavate the trench to a minimum width of six pipe diameters centered over the pipe. "Suitable Backfill" shall then be placed and compacted in courses as described under the section for bedding to the new trench width.

For unstable trench (Five pipe inside diameters) The contractor shall provide additional crushed stone and "Suitable Backfill" to the over excavated trench walls.

B. Ductile Iron Pipe

The contractor shall provide a higher class of bedding and replace the over excavated material above the bedding with suitable backfill.

C. Structures

The contractor shall provide additional "Suitable Backfill" to the trench walls and compact to 95% Maximum Dry Density as determined by the Modified Proctor Test.

3.09 EXCAVATION AND PROTECTION OF PROPERTY

Excavations shall be shored, braced, supported or sheeted as conditions may warrant. The contractor shall support and protect all existing property, pavement, sidewalk, curb, pipes, poles and structures of any kind that lie outside of the trench limits. The contractor shall also support and protect all utilities, house laterals and drains that cross the trench. If the contractor elects to remove, replace or relocate any of the above poles, utilities or structures he shall be responsible to make all arrangements and obtain all necessary permits and approvals from the owners of the facility involved. The contractor shall be responsible to restore any damaged or displaced property to the pre-existing condition, all with the full knowledge and approval of the owners of the property. This applies equally to all above and below ground properties, utilities, structures and appurtenances involved.

The contractor shall backfill the trench in 6 inch layers to the same lift level as the bottom of any partially or totally exposed utility line that is within or adjacent to the trenching operations. Thereupon the contractor shall compact the material beneath and around the utility to achieve a bedding condition at least equivalent to the in situ condition. The utility must be properly supported during the entire trenching operations, backfilling and utility bedding operation. Where sewers are tunneled beneath existing ACP water mains, the section of water main exposed to trench shall be removed and replaced with DIP, to a limit of 12" beyond virgin ground each side of trench.

3.10 BACKFILL IN TRENCH

The strict requirements of this section to backfill in 12" layers to the original surface of the ground are intended to apply to existing public roads. In new developments, backfill shall be placed in strict conformance with the bedding requirements but above the bedding area, backfilling and tamping is a matter between the owner and contractor, however, the Township will not accept the sanitary system where settlement has occurred over sewer trenches or around manholes until properly repaired.

As soon as practicable after the pipe has been bedded, the backfilling shall begin and shall continue without delay.

Backfilling shall proceed as promptly as is consistent with non-injury to the pipe or structures. Where the trench is in a paved area or an area to be paved or in an unpaved vehicular or pedestrian traveled way, or the shoulder of a paved roadway, backfill shall be placed and compacted in 12" lifts. The final twenty four (24) inches of trench backfill shall be compacted to a minimum of 95% maximum dry density as determined by the Modified Proctor Test as specified in Section 3.13.

Care shall be taken in the use of mechanical tampers not to injure or move the pipe or to cause the pipe to be supported unevenly. Large masses of backfill material shall not be dropped into the trench in such manner as to endanger the pipe.

Frozen material shall not be placed in the backfill, nor shall backfill be placed upon frozen material. Previously frozen material shall be removed before backfill is placed.

No compacting shall be done when the material is too wet to be compacted properly. At such times the work shall be suspended until the previously placed and new materials have dried out sufficiently to permit proper compaction, or such other precautions shall be taken as may be necessary to obtain compaction.

### 3.11 DISPOSAL OF MATERIAL

This paragraph is intended to apply to existing public roads. In new developments, disposal of excess material shall be done so by the contractor at the owner's direction.

Material excavated shall be disposed of in building embankments, making fills, and grading around the work as may be directed, and to the lines and grades established by the engineer.

Excess material shall be directly loaded on trucks and disposed of by the contractor in approved locations outside of the working areas.

In streets or adjacent to private property, material shall be stored at such locations as will not unduly interfere with traffic of any nature and in no case shall material be stored in locations which will cause damage to existing improvements.

### 3.12 TEMPORARY BRIDGES AND CROSSINGS

The contractor shall, where required to expedite the work, or where required to maintain traffic, or where otherwise ordered by the engineer, construct temporary bridges, or walkways, of adequate sized members to safely carry the loads which may reasonably be anticipated.

3.13 WORK IN LAWN AREAS

Where the work is in easements located within privately owned lawn areas, rear yards, etc., the contractor shall make every effort to minimize disturbance to the area. All trees shall be boxed or otherwise protected. Excavated material shall be stored on tarpaulins or other means used to prevent it from being spread on the ground. Backfill shall be completed on the same day. Only under unusual circumstances shall a trench be allowed to remain open overnight. Topsoil shall be removed and stored separately, and upon completion of backfill shall be evenly spread over the disturbed area. If settlement occurs, the contractor shall bring in additional topsoil to bring the trench up to grade.

All disturbed lawns, trees, shrubs, bushes, planting, fences, walls, driveways, walkways etc., shall be restored to the satisfaction of the owner. Claims made by affected owners shall be withheld from payments due the contractor until such claims are settled. It is suggested that the contractor take "Before and After" photographs of all such areas.

3.14 BEDDING

Reference Specifications

ASTM D-2321 Standard Practice for Underground Installation of PVC pipe.

ASTM D-448 Standard Classification for Sizes of Aggregate for Road and Bridge Construction.

ASTM D-698 test for moisture-density relations of soils, using 5.5 lb. rammer and 12 inch drop.

ASTM D-1557 test for moisture-density relations of soils, using 10 lb. rammer and 18 inch drop.

Article 901.09 Table 901-2 of the NJDOT Standard Specifications for Road and Bridge Construction, latest edition

Materials

PVC pipe shall utilize 3/8" clean stone, or stone crushings to conform to AASHTO Designation M43-88 for the initial backfill and bedding materials. In no case shall less than a Class III material be used for bedding and haunching material. When the installation of pipe occurs in unstable soil or excessive groundwater, the Township Engineer shall make a determination regarding special precautions to be utilized.



### Concrete Cradle

Where an existing storm or gravity sewer pipe cross over and within six (6) inches of the gravity sewer pipe, the contractor shall, when directed by the engineer, support the existing pipe on a 3,000 psi concrete cradle extending from the springline of the gravity sewer pipe to the springline of the existing pipe. The cradle shall have a length equal to the outside diameter of the gravity sewer pipe plus two (2) feet and a width equal to the outside diameter of the gravity sewer pipe plus one (1) foot, centered on the respective pipes. All concrete work shall conform to the requirements of Section 3.20, Cast-In-Place Concrete.

Where the required separation between sewer mains and water mains cannot be maintained at 10 feet laterally or 18 inches horizontally, the sewer shall be constructed with watertight joints at least 10 feet on either side of the crossing. In addition, one full length of sewer pipe should be located so both joints will be as far from the water main as possible.

### Methods of Construction

#### 1. General

Pipe shall be bedded true to line and grade with a uniform and continuous support from a firm base. No blocking shall be used to bring the pipe to grade.

#### 2. Polyvinyl Chloride Pipe

##### A. Stable Bedding Foundations

The installation shall follow the recommendations of ASTM D2321. The first or foundation course shall initially be placed to a point above the pipe bottom, such point being determined by the depth of loose material resulting from the preparation of this course, and the amount of compaction required to bring the material to grade.

Bell holes shall be excavated in the first course to allow for unobstructed assembly of the joint. Care shall be taken that the bell hole is no larger than that necessary to accomplish proper joint assembly while maintaining the pipe support. When the joint has been made, the bell hole shall be carefully filled to provide adequate support for the pipe throughout its entire length.

In the second or haunching course care shall be taken to ensure that sufficient "bedding material" has been worked under the haunch of the pipe to provide adequate side support. Precautions shall be taken to prevent movement of the pipe during the placement of the material under the pipe haunch.

B. Unstable Trench

Where unsuitable material is encountered as determined by the engineer either beneath the bedding or lateral to the trench bedding, the bedding width shall be a minimum of five times the pipe diameter as measured centered on the pipe. Unsuitable material beneath the pipe shall be removed to a depth as directed by the engineer and backfilled with material conforming to the requirements for Suitable Bedding.

The Suitable Bedding shall be initially placed to the approximate bottom of the pipe with the objective of providing a level and uniform foundation for the pipe. Care shall be exercised in placing the Suitable Bedding in the subsequent haunching course to ensure that sufficient material is worked under the haunch of the pipe to provide adequate side support. Care shall further be exercised to prevent movement of the pipe during placement of the material beneath the pipe haunch. For the placement of the final course of Suitable Bedding to 12" above the top of the pipe, care shall be exercised to protect the pipe from the placement of the Suitable Backfill.

The final bedding "Suitable Bedding" material course shall be hand or mechanical tamped to the recommended requirements of the referenced standard.

3.15 PIPE MATERIALS

Scope of Work

Pipe materials shall include all types of pipe necessary for construction as indicated and as specified.

Reference Specifications

ANSI A21.4 (AWWA C104) Standard for Cement Mortar Lining for Ductile-Iron and Gray-Iron Pipe and Fittings for Water.

ANSI A21.5 (AWWA C105) Standard for Polyethylene Encasement of Ductile-Iron and Gray-Iron Pipe and Fittings for Water.

ANSI A21.11 (AWWA C111) Standard for Rubber-Gasket Joints for Ductile-Iron and Gray-Iron Pressure Pipe and Fittings.

ANSI A21.15 (AWWA C115) Standard for Flanged Ductile-Iron and Gray-Iron Pipe with Threaded Fittings.

ANSI A21.51 (AWWA C151) Standard for Ductile-Iron Pipe, Centrifugally Cast in Metal Molds or Sand Lined Molds, for Water or other Liquids.

ASTM C76 Specification for Reinforced Concrete Culvert, Storm Drain, and Sewer Pipe

ASTM C 700 Specification for Vitrified Clay Pipe, Extra Strength, Standard Strength, and Perforated.

ASTM D 1784 Standard specification for rigid Polyvinyl Chloride (PVC) compounds and Chlorinated Polyvinyl Chloride (CPVC) plastic pipe (SDR-PR)

ASTM D 1785 Specification for Poly (Vinyl Chloride) (PVC) Plastic Pipe, Schedules 40, 80, 120

ASTM D 2241 Specification for Poly (Vinyl Chloride) (PVC) Pressure-Rated Pipe (SDR-Series)

ASTM D 2321 Practice for Underground Installation of Flexible Thermoplastic Sewer Pipe

ASTM D 2444 Test Method for Impact Resistance of Thermoplastic Pipe and Fittings by Means of a TUP (Falling Weight)

ASTM D 3212 Standard specification for rigid Polyvinyl Chloride (PVC) compounds and Chlorinated Polyvinyl Chloride (CPVC) plastic pipe (SDR-PR)

ASTM D 3034 Standard for type PSM Polyvinyl Chloride (PVC) sewer pipe and fittings.

ASTM F 477 Specification for Elastomeric Seals (Gaskets) for Joining Plastic Pipe

ASTM F 679 Specification for Poly (Vinyl Chloride) (PVC) Large-Diameter Plastic Gravity Sewer Pipe and Fittings.

ASTM F 789 Specification for type PS-46 Poly (Vinyl Chloride) (PVC) Plastic Gravity Flow Sewer Pipe and Fittings.

ASTM F 794 Specification for Poly Vinyl Chloride (PVC) Large Diameter Ribbed Gravity Sewer Pipe and Fittings based on Controlled Diameter.

ASTM F 949 Specification for Poly (Vinyl Chloride) (PVC) Corrugated Sewer Pipe with Smooth Interior and Fittings.

#### PVC Sewer Pipe

All PVC pipe shall meet the requirements of ASTM D 3034 (SDR-35). In addition to straight pipe, the contractor shall furnish all fittings, test plugs, adapters, elbows, tees, wye-tees, wyes, caps and plugs of the same material as the pipe required to complete the work. Each pipe and fitting shall be clearly marked on the outside surface with the trade name, pipe size, and class designation. Stubs shall be

furnished in nominal lengths of five (5) feet. The plastic material from which the pipe and fittings are extruded shall be impact types of PVC, unplasticized, having high mechanical strength, and chemical resistance conforming to Type 1, Grade 1 of the specification for rigid polyvinyl chloride compounds, ASTM D1784. The pipe and fittings shall be free from defects, such as bubbles or other imperfections, in accordance with accepted commercial practice. Test results demonstrating that the pipe meets ASTM D2444 for impact and ASTM D2321 for deflection and pipe stiffness, shall be provided when requested by the Owner or authorized representative. Joints shall conform to ASTM D3212. Rubber ring gaskets shall conform to ASTM F477. The gasket shall be the sole element depended upon to make the joint watertight.

#### Ductile-Iron Pipe

Ductile-Iron Pipe shall be manufactured in accordance with ANSI A21.51 and shall be thickness Class 50 except where otherwise specified. Mechanical joint or push-on type joints shall conform to ANSI A21.11. Ductile-Iron Pipe and fittings shall be cement mortar lined in accordance with ANSI 21.4.

Fittings shall conform to pressure ratings of 250 psi for pipe 12 inch and under and 150 psi for pipe over 12 inches.

All joints shall be push on type except at changes in direction. Where changes in direction occur joints shall be super-lock as manufactured by Clow Corporation, Bensenville, Illinois, Loktyte as manufactured by U.S. Pipe and Foundry Co., Birmingham, Alabama, Lok-Fast as manufactured by American Cast Iron Pipe Co., Birmingham, Alabama or equal. Restrained length shall be as indicated on the detail drawings.

The pipe shall be furnished with the necessary rubber gaskets.

Pipe shall be lined in accordance with ANSI A21.4 and the section on pipe linings and coatings.

#### Service Lateral

The house connection or lateral from the street main to the curbside cleanout shall be considered an integral part of the sanitary sewer system. The following materials are acceptable for use as a lateral or house connection:

1. Four-inch DI Pipe, Class 52 for Single Family Units
2. Four-inch PVC Pipe, SDR 35 for Single Family Units
3. Minimum six-inch DI Pipe, Class 52, or PVC Pipe (SDR 35) for commercial, industrial and multiple unit structures.

Wye connections shall be the same material as the sewer main. Saddles shall be used only for connection to an existing main. Bends in house connections shall be made using standard fittings. A cleanout and riser shall be provided in the lateral at a location as designated by the owner within the Township ROW or easement area. Inspection cleanouts or observation tees shall be fitted with metallic caps or non-metallic caps and metallic plugs, when located within the ROW or easement. Caps shall have a depressed or inverted nut.

#### Flexible Couplings

The flexible couplings to be utilized when connecting polyvinyl chloride pipe to existing pipe at special manholes, shall be steel transition couplings. Transition couplings shall be Style 162 as manufactured by Dresser Industries, Style 413 as manufactured by Smith Blair or equal. Bolts and nuts shall be high strength stainless steel.

#### Steel Casing Pipe

Steel casing pipe shall be manufactured in accordance with ASTM A 139 or A 252. Casing pipe shall have a diameter at least eight (8) inches larger than the greatest diameter of the carrier pipe, joint or coupling.

#### Bulkheads

Where required, the contractor shall install watertight bulkheads.

Bulkheads to be installed shall include a 4 inch C.I. flanged nipple and a 4 inch gate valve with invert matching that of the pipe, suitable for dewatering the pipe.

#### Fittings and Specials

Beveled pipes, bends, and tees, and other special pipes shall conform to the specifications for straight pipe. Where special design or construction is necessary for such pipe the design and construction shall be subject to the approval of the engineer.

When the radius of curvature of the line is less than the minimum specified by the manufacturer for laying straight lengths of pipe, bends of the proper deflection shall be used

### 3.16 PIPE LININGS AND COATINGS

#### Scope of Work

Pipe Linings and Coatings shall include all work, materials and equipment necessary to construct the various pipe linings and coatings specified.

#### Reference Specifications

ANSI A21.4 Cement mortar lining for cast-iron pipe and fittings for water.

ANSI A21.5 Polyethylene encasement for gray and ductile iron piping for water and other liquids.

#### Ductile-Iron Pipe

All Ductile-Iron Pipe and fittings shall be cement lined inside in conformance to ANSI A21.4. The lining shall be double thickness (1/8 inch) to the ends of the pipe and shall be provided with a bituminous seal coat. Pipe shall receive a standard bituminous foundry dip on the outside. The weight and class shall be conspicuously indicated by the manufacturer on the outside of the pipe. Ductile Iron Pipe installed in corrosive soils shall be wrapped with polyethylene in accordance with ANSI A21.5.

### 3.17 PIPE INSTALLATION

Materials: Rubber gaskets shall conform to the requirements specified under pipe materials. Gasket lubricant shall conform to the gasket manufacturer's recommendations.

Installation: "Suitable Bedding" material shall then be placed in two separate lifts (third & fourth courses). Upon completion of the placement of the backfill material for each course the material shall be compacted by hand or with mechanical tampers to a minimum of 95 percent of Modified Proctor Density. Care should be taken to avoid contact between the pipe and the compaction equipment. Compaction shall be done in such a way so that the equipment is not used directly over the pipe until sufficient backfill has been placed so that the equipment will not have a damaging effect on the pipe.

Handling: Pipe and accessories shall be handled with care and shall not be dropped, or bumped against pipe or accessories already on the ground or against any other object on the ground. The contractor's methods for the handling of pipe and fittings shall conform to the pipe manufacturer's recommendations.

Cleaning: The interior of all pipe and fittings shall be thoroughly cleaned of all foreign matter before being installed and shall be kept clean until the work has been accepted. All joint contact surfaces shall be kept clean until the jointing is completed.

Every precaution shall be taken to prevent foreign material from entering the pipe during installation.

Groundwater shall not be allowed to rise around the pipe until the trench is backfilled. Dewatering operations must be continuous for as long as the trench is open.

Whenever pipe laying is stopped, the open end of the pipe shall be closed with a snug fitting plug.

Alignment: Pipe shall be laid to the lines and grades shown on the plans. No deviation shall be made from the required line or grade except with the written consent of the engineer.

Laying Pipe: Pipe shall be protected from lateral displacement by pipe bedding material. Under no circumstances shall pipe be laid in water and no pipe shall be laid under unsuitable weather or unstable trench conditions.

Pipe shall be laid from downstream to upstream with the bell ends facing the upstream direction except when reverse laying is specifically permitted by the engineer.

Joining: Joining pipe shall be performed in accordance with manufacturer's recommendations. Methods and equipment shall be utilized which are capable of making joints without damage to the pipe.

Connection to Existing Line: Where connections are made between new work and existing piping, such connections shall be made using fittings or adapters as recommended by the pipe manufacturer.

Cutting Ductile Iron Pipe: Cutting shall be done in a neat manner, without damage to the pipe or to the cement lining. Cuts shall be smooth, straight, and at right angles to the pipe axis. After cutting, the end of the pipe shall be dressed with a file to remove all roughness and sharp edges.

Mechanical Joints and Restrained Joints: Mechanical joints and restrained joints shall be carefully assembled in accordance with the manufacturer's recommendations. If effective sealing is not obtained, the joint shall be disassembled, thoroughly cleaned, and reassembled. Over-tightening bolts to compensate for poor installation practice will not be permitted.

### 3.18 PIPE TESTS AND INSPECTION

#### Control Tests

The Township Engineer shall observe all control tests and must receive a minimum of a 48 hour notification before any tests are performed.

The Township Engineer may sample and test any pipe after delivery and so reject all pipe represented by any sample which fails to comply with the specified requirements.

The engineer shall check any pipe for pits, blisters, rough spots, breakage or other imperfections. Any pipe which has been rejected because of the above shall be conspicuously identified and immediately removed from the construction site.

### Visual Inspection

Each section of the installed sewer shall be visually inspected by the engineer prior to testing.

The contractor shall provide all personnel and facilities the engineer will need to inspect the construction.

The pipe shall be true to both line and grade, shall contain no broken pipe, shall show no leaks, shall show neither obstructions nor the projection of connecting pipes into the main pipe, and shall contain no debris or other deposits which will in any way reduce the full cross-section area of the pipe.

Any section of sewer pipe which does not comply with these inspection criteria, shall be promptly corrected and replaced or repaired by the contractor. Such methods as are employed for the correction shall be reviewed by the engineer.

Upon completion of the correction of any and all defects uncovered in this inspection, the contractor may proceed with the necessary infiltration and exfiltration testing of the gravity sewer portions of the contract.

### Video Inspection

Prior to submitting an Application for Certification of Completion and release of the performance guarantee, all sewer mains must be Jet Vac cleaned and the sewer mains and laterals from the sewer main to the cleanout must be TV inspected.

The Applicant shall furnish Two (2) copies of CD or DVD disks of all televised sanitary sewers to the Engineer. The discs shall be clearly labeled with the date and time of the inspection and the section of sewer inspected. In addition to the disks, Two (2) copies television inspection log reports shall be submitted to the Engineer. The log reports shall describe and locate all defects and service connections in sufficient detail to determine the condition of the pipe without having to review the recording. The log reports shall be cross-referenced with disks with disk number, manhole number, and disk footage with respect to manhole section, actual distance from manholes to defects, service connection, and repairs.

The contractor shall notify the Engineer 72 hours before the TV inspection is to occur.

### Infiltration and Exfiltration Tests For Gravity Sewers

Preparatory to testing for water tightness, the contractor shall remove all debris from manholes and shall thoroughly flush sewers in such a manner as to permit no sand, sediment, stones, or other foreign materials from entering completed sections of the pipeline. All sewers, fittings and manholes shall be tested and shall satisfactorily meet the test requirements prior to final acceptance of the work. The



contractor shall furnish all labor, weirs, pumps, valves, gauges, testing materials and equipment and shall perform the tests to the satisfaction of the engineer.

The rate of infiltration/exfiltration shall not exceed 100 gallons per inch of inside diameter per mile of pipe per 24 hours. Repairs to pipe shall be made in kind, chemical grouting or repair clamps will not be permitted. If leakage exceeds the specified amount, the contractor shall make the necessary repairs or replacements required to permanently reduce the leakage to within the specified limits, and the test shall be repeated until the infiltration conforms to the requirements specified herein.

Where low pressure air testing of sewer lines is allowed by the Township, the following procedure shall be followed. The test shall be observed by the Township Engineer. Low pressure air test shall conform to the Uni-Bell Plastic Pipe Association Recommended Practice UNI-B-6, "Low Pressure Air Testing of Installed Sewer Pipe," except as modified herein.

Procedure:

1. Clean the pipe to be tested by a method approved by the engineer.
2. Plug all pipe outlets with suitable test plugs. Brace each plug securely.
3. If the pipe to be tested is below the ground water level, determine the difference between the ground water level and the pipe to be tested by a method approved by the engineer.
4. Add air slowly to the plugged pipe to be tested until the internal pressure is raised to 4.0 psi above the ground water pressure.
5. Check exposed pipes and plugs for abnormal leakage and make any necessary repairs. Do not loosen the plugs until the internal pressure has been relieved.
6. After an internal pressure of 4.0 PSIG is obtained, allow at least two minutes for air temperature to stabilize, adding only the amount of air required to maintain pressure.
7. After the two minute period, completely disconnect the air supply from the pipe to be tested.
8. Once the air supply has been disconnected, the test duration shall be initiated.
9. The test duration shall be five minutes at a test pressure of 5 PSIG with a maximum allowable pressure drop of 0.5 PSIG.

10. If leakage exceeds 0.5 PSIG during the five minute testing interval, the leaks shall be located, repaired, and retested according to the above test procedure.
11. The contractor shall furnish all equipment, plugs, compressor, hoses, valves, gauges, etc. Gauges shall be of the recalibration type having a maximum range of 0 to 20 PSIG and a minimum range of 0 to 5 PSIG over a 120 degree arc and such that the pressures to be measured fall in the center 50% of the scale. All gauges shall be accurate to within +1% of full scale range. All equipment shall be subject to approval by the engineer.

#### Deflection Testing

The Contractor shall furnish all equipment and personnel to conduct deflection testing on portions of PVC pipe installed. The deflection of the PVC sewer pipe shall not exceed five percent (5%) of the inside pipe diameter. Deflection testing shall not be conducted earlier than seven (7) days after placement and compaction of the backfill.

The vertical deflection shall be checked by manually pulling a go, no-go deflection testing mandrel through the pipe. The mandrel shall be specifically designed for this purpose, and the Contractor shall submit shop drawings to the Engineer detailing the type of mandrel to be used. The mandrel shall be as manufactured by Armco, Inc., or equal, and shall have the specified accuracy in all positions or rotations.

The Contractor shall conduct all deflection testing in the presence of the Engineer. Should any pipe section exceed the maximum deflection specified, the Contractor shall undertake any remedial action as required to reduce the deflection to within that limit.

### 3.19 MANHOLES

#### Scope of Work

This section covers precast, concrete block, drop and special manholes. Manholes shall be constructed complete with all covers, steps, fittings and appurtenances in accordance with the detail drawings.

#### Reference Specifications

ASTM A 48 Standard specification for gray iron castings

ASTM C 32 Standard specification for sewer and manhole brick (made from clay or shale).

ASTM C 139 Concrete masonry units for construction of catch basins and manholes.

ASTM C 150 Standard specification for Portland Cement

ASTM C 207 Standard specification for hydrated lime for masonry purposes.

ASTM C 478 Standard specification for precast reinforced concrete manhole sections.

#### Materials

Precast sections shall conform to the size and shape indicated on the detail drawings. Precast sections shall conform to ASTM C 478, except as specified herein. All concrete shall be 4000 psi. Precast concrete tops shall be eccentric cone or flat slab top conforming to the detail drawings. The contractor will make inlet openings with a coring machine of all existing manholes in which stubs have not been provided for the connection. Jackhammers or similar devices shall not be accepted. All inlet and outlet openings shall have flexible manhole sleeves. Diameter of cored openings shall be the flexible sleeve manufacturer's specified opening diameter for the given pipe size. All precast openings shall have the flexible sleeve integrally cast in the manhole wall. Flexible manhole sleeves shall be A-lok or Z-loc boots in accordance ASTM C923.

Portland Cement shall conform to ASTM C 150, for Type II cement.

Hydrated Lime shall conform to ASTM C 207 and shall be Type S.

Sand shall be a fine aggregate concrete sand passing on eight (8) mesh screen.

Mortar shall be one (1) part cement, 1/2 part lime and three (3) parts sand.

Clay or shale brick for manhole construction shall conform to AASHTO M114, Grade MW, except as indicated in the following. The bricks shall be between 7.75 inches and 8.25 inches in length. The width of the brick shall be between 3.50 inches and 3.88 inches. The bricks shall be between 2.10 inches and 2.38 inches in depth. The maximum water absorption, by five hour boiling shall be 14% for the average of five (5) bricks and 16 % for individual bricks.

Concrete block shall be solid, precast segmental concrete masonry units. The blocks shall be either rectangular in shape, or be curved blocks, whichever is appropriate to the shape of the structure. The blocks shall be between 12 and 18 inches long, 5 and 8 inches high, and not less than 8 inches in width. All blocks shall have an interlocking-type joint at the ends. All blocks shall be sound and free from all cracks or other defects. Special dimensional blocks may be used where necessary to accommodate the change in cross sectional area near the top of the manhole, or where reduced height is required to permit the setting of the casting in not more than 1/2 inch thick mortar bed. Blocks shall not be cut to accommodate the maximum mortar bed thickness of 1/2 inch.

Concrete brick shall conform to the dimensional requirements for clay or shale brick. Otherwise, concrete brick shall conform to the requirements for concrete block.

Manholes shall be supplied with flexible, watertight adaptors, such as inserts or gaskets, conforming to ASTM C 923 and suitable for the pipe material used.

All manhole castings shall meet the requirements of ASTM A 48 for Class 30 castings. Standard manhole frame and cover shall be Campbell Foundry Company number 1202 or Flockhart Foundry Company drawing number 18590 or equal, watertight manhole frame and cover shall be bolted and gasketed conforming to Campbell Foundry Company number 1539-B-W.T. or Flockhart Company drawing number 24876, or equal. All casting for manhole covers and frames shall be close grained, tough gray iron free from cracks, holes, swells, and shrinkage distortion. All manhole castings shall be made accurately to the pattern and to the dimensions specified with carefully machined bearing surfaces. Allowances shall be made in the patterns so that specified thicknesses shall not be reduced. All lids that "rock" and do not lie solid after construction is finished will be rejected and shall be replaced by adequate lids at no additional cost to the owner. No plugging, burning-in or filling will be allowed. All castings shall be carefully coated, both inside and out, with coaltar-pitch varnish. All covers shall be solid design and shall be supplied with special non-penetrating, watertight pick-holes. The word "SEWER" shall be cast integrally into the manhole cover.

Manhole steps shall be polyethylene, drop front design, built into the walls and set in a straight alignment so as to form a continuous ladder with a maximum distance of twelve inches between steps. The portion of the aluminum steps and ladder anchor bolts that are embedded in the concrete shall be coated with coaltar-pitch varnish.

#### Methods of Construction

Pre-cast manhole base sections shall be set on a crushed stone level foundation as indicated on the plans. Backfill material, to be used when the engineer deems the excavated material unsuitable, shall conform to Section 3.10. Base sections shall be oriented properly to allow pipe connections to be made. Joints between sections shall be cleaned and primed in accordance with the recommendations of the gasket manufacturer. The base and first section shall be monolithically cast. Cracked manholes shall not be used. Gaskets shall be placed in such a manner as to produce a continuous Waterproof seal between the sections. Sections shall be placed to produce a truly vertical structure and with the steps uniform about a vertical axis. All lifting holes shall be sealed, full depth, with manufacturer's plugs and mortar. Pipes entering pre-cast manholes shall be set securely in the pre-cast opening and at the correct line and grade. Flow channels and benches shall be carefully formed of concrete as indicated on the detail drawings.

The interior and exterior joint space of all manhole risers shall be mortared or filled with a joint compound. The joint filler shall be Butyl Lok.

The top riser section of all manholes shall terminate not less than 18 inches below grade, and be brought to grade by using not more than three (3) courses of brick or block. Masonry brick, concrete block, concrete brick, or half rings may be used to make vertical adjustments to rims. All work shall be laid plumb, level and true. Manhole frames shall be set at the required grade and shall be securely attached to the top of the manhole shaft with a cement mortar bed and fillet as shown on the detail drawings. Castings shall be cleaned and scraped of all foreign matter to insure a close and proper fit.

At any manhole where the invert of any inlet is more than 2 feet above the outlet invert, a drop manhole shall be constructed. Drop pipe sections shall be supported with Type 316 stainless steel bands bolted to the walls by means of 1/2" diameter stainless steel anchor bolts. Drop manhole connections, shall conform to the detail drawings, and the materials and installation methods used shall be as specified herein for standard manholes.

All manholes shall be internally lined with a white epoxy coating (Ponamid 65). The exterior coating shall be green epoxy coating "Enviro Green". The coating(s) shall be applied in a minimum of two (2) coats and have a total thickness of 16 mils. All coating shall be done in strict accordance with the manufacturer's instructions and shall be performed in a manner satisfactory to the engineer.

The channels and benches shall receive an epoxy coating. The coating on the benches shall receive an additive for non-skid finish. The coating shall be Endcor 785 (Gray) as manufactured by the Dampney Company, Sikagard 667 as manufactured by the Sika Chemical Corp, or equal. All surfaces shall receive a minimum of two (2) coats. The total dry film thickness shall be 12 mils.

#### Expansion Bolts

Wherever compound anchors such as "cinch" anchors or expansion bolts are evidently required to secure members or parts of equipment, cinch anchors as made by the National Lead Company, the Start Expansion Bolts Co., the Phillips Drill Co., or equal shall be furnished and used. The number of units used shall be as required by the stress on the bolt. Bolts shall be hot dipped galvanized, after which the threads shall be run down. No wooden plugs in concrete or masonry shall be used for attachment of metals.

#### Anchor Bolts

For mounting items on concrete, anchor bolts shall be low-carbon steel, unless specified otherwise elsewhere herein, with standard threads and bent to the shape indicated on the drawings to provide secure anchorage in the concrete. Ferrous anchor bolts and nuts used outside the building shall have a heavy hot-dipped galvanized coating.

### 3.20 CAST-IN-PLACE CONCRETE

#### Scope of the Work

The work included under this section consists of, but not limited to, concrete for foundation mats, shaping of manhole inverts and pipe encasements.

It is anticipated that the concrete used for sewer construction will be limited to simple structures and will be supplied via transit mix trucks. Although the specification is brief, the contractor will be required to furnish same quality materials and provide comparable workmanship as required for major concrete structures.

#### Reference Specifications

Following specifications shall be considered part of these specifications. Reference to the published standard shall, in all cases, be to the latest edition of such standards.

ACT Manual 301 Specification for Structural Concrete for Buildings.

ACI Manual 304 Recommended Practice on Measuring, Mixing, Transporting and Placing Concrete

ACI 3.18 Building Code Requirements for Reinforced Concrete

ACI 211.1 Recommended Practice for Selecting Proportions for Concrete

ACI 305 Recommended Practice for Hot Weather Concreting

ACI 306 Recommended Practice for Cold Weather Concreting

ACI 347 Recommended Practice for Concrete Formwork

ACI 503 Guide for Use of Epoxy Compound with Concrete

ACI 214 Recommended Practice for the Evaluation of Compression Test Results of Field Concrete

ACI 315 Manual of Standard Practice for Detailing Reinforced Concrete Structures

#### Material

Reinforcing: Reinforcing steel shall meet the requirements of ASTM Specification A-15 and ASTM A-305 for deformed steel bars of intermediate grade billet steel.

Cement: Cement shall conform to ASTM Designation C-150 as revised, TYPE II. An air entraining agent approved by the engineer shall be added to the concrete mix.

Aggregates: Aggregates shall conform to the Standard Specifications for Concrete Aggregates, ASTM Designation C-33. Sand shall be medium gradation with fineness modulus of 2.60-2.90. Coarse aggregate shall not exceed 1-1/2 inch for mass concrete and 3/4 inch for reinforced slabs.

#### Construction Methods

Forms: The contractor shall design, furnish, and erect forms as required for concrete structures. Forms shall be of sufficient strength and adequate to retain concrete to design dimensions. Special steel ring forms may be required for cast-in-place manhole bases to accept precast wall sections. All forms shall be removed prior to backfilling.

Reinforcing steel: Fabrication of all steel reinforcement shall conform to the requirements of the American Concrete Institute, "Building Code Requirements for Reinforced Concrete" (ACT-318).

Reinforcing bars shall be placed accurately in the positions shown on the drawings and held firmly during the placing and setting of concrete. When placed in the work, reinforcing bars shall be free from dirt, grease, paint or other foreign substances, loose mill scale, and heavy flaky rust that can be removed by firm rubbing with burlap or equivalent treatment. After being placed, the reinforcing bars shall be maintained clean until completely embedded in the concrete. Care shall be exercised to prevent any disturbance of the reinforcing bars in concrete that has already been placed.

Reinforcing bars shall be supported in position by means of concrete or metal chairs, metal hangers, metal spacers, or other satisfactory metal supports. The legs of the bar supports shall be either galvanized or plastic coated. The use of broken stone, metal pipe and wooden blocks will not be permitted. Galvanized metal chairs or concrete chairs shall be used for supporting reinforcing on sub-grade.

Reinforcing bars shall be tied at all intersections except where spacing is less than 1 foot in each direction when alternate intersections shall be tied; such ties shall be made with no. 16 gauge wire.

Concrete shall not be placed until reinforcing bars have been inspected in place by the engineer.

#### Concrete

Concrete shall attain a 28-day strength of not less than 3,000 psi. Concrete proportioning, mixing, placing, curing and protection shall be in accordance with accepted practice as amplified in "Design and Control of Concrete Mixtures" by the Portland Cement Association.

Truck mixers shall be permitted only when the mixers and their operation produce a batch as discharged which meets an approved consistency, mix and grading.

Water shall not be added other than that which may be required to bring the batch to the proper consistency, on arrival at the forms. At least 25 revolutions of mixing shall be provided after any such addition of water. Mixers shall rotate not less than 80 revolutions at 8 RPM for each batch. All revolutions over 100 shall be at 4 RPM, except that the reduced speed will not be required when water is admitted for mixing on arrival of the mixer at the forms. Retempering of concrete will not be permitted. The slump of the concrete shall not exceed 4 inches.

Truck mixers shall be equipped with (1) accurate means of measuring mixing water used from the tank on the mixer, (2) means of verifying the accuracy of this water measurement, (3) a device for counting the number of revolutions of the drum, and (4) facilities for addition of water under such pressure and so directed that the water will be added uniformly from front to back of the mixer.

All surfaces of foundations upon which concrete is to be placed shall be moistened immediately before placement of concrete but shall be free from standing water, mud, or debris, when the concrete is placed.

Concrete shall be consolidated by vibration to the maximum workable density so that it is free from pockets of coarse aggregate and entrapped air, and closes against all surfaces of forms and embedded materials.

Unless inspection is waived, in writing, concrete shall be placed only in the presence of the engineer.

Construction joints shall be clean and damp, but not wet, when covered with fresh concrete. Cleaning shall consist of the removal of all laitance, loose or defective concrete, coatings, sand, scaling compound, and other foreign material. The contractor may, at his option, modify the amount and location of construction joints with the approval of the engineer.

Concrete surfaces shall be cured by water curing for 7 days except slabs on grade and underground structures which may be cured by an approved pigmented membrane curing compound.

#### 4. Technical Specifications – Pumping Stations

##### 4.00 GENERAL

Pumping stations shall comply with N.J.A.C. 7:14A-23.10, 23.11, and 23.12. Specifications for pumping stations shall include information as to the following required items, to be included within the design of the station and delineated within the specifications. In general pumping stations shall be of similar design to those constructed by the Township.

- A. Protection against clogging of pump to be provided either by a bar screen, comminutor or by pump design.



- B. Standby power, either through the use of emergency drive units or through the use of emergency generating facilities shall be provided.
- C. Adequate automatic alarms compatible with Township's system shall be provided.
- D. All pumping stations shall be adequately protected against flooding and have a means of accessibility by vehicle at all times.
- E. Adequate lighting shall be provided. Explosion proof fixtures shall be used in the wet well.
- F. Water facilities shall be provided to allow wash down of the pumping facility. However, under no circumstances will possible cross connection be permitted. Wash down facility shall be protected with an Reduced Pressure Zone (RPZ) backflow prevention device.
- G. All pumping units shall as a minimum be provided in duplicate.
- H. Combination of pumping units or a separate pumping unit shall provide for maximum anticipated flows.
- I. Flanged plug valves on the discharge side of a pump shall be provided. Flanged check valves shall be provided on the discharge side of the pump.
- J. A bypass connection with appropriate valves and quick disconnect fitting shall be provided in the force main immediately after the valve pit.
- K. Adequate drainage of valve pits through the use of drains or sump pumps shall be provided.
- L. Adequate means shall be included for access to wet wells and for the removal of all equipment.
- M. Electrical equipment, including motors, shall be protected from flooding and shall comply with Fire Underwriter's Regulations and National Electrical Codes.
- N. Suitable landscaping, fencing and vehicle gates shall be provided around all pumping stations unless directed otherwise by the Township Engineer.

4.01 GENERAL DESCRIPTION

A section shall be included to present a description of the facility proposed and shall include references to equipment to be installed.

Example Description

The contractor shall furnish and install one complete automatic, underground sewage pumping station, including all required equipment and accessories, as shown on the drawings. The principal items of equipment in the pumping station shall include: two submersible, constant speed electric motor driven, non-clog sewage pumps, valves, piping, central control panel and transfer switches with circuit breakers, motor starters and automatic pumping level controllers, lighting, sump pump, dehumidifier, and wiring. Work shall include wet wells and appurtenances, electric and water services, excavation, dewatering, sheeting, backfill, concrete base slab, clean-up, landscaping, painting and testing, and cathodic protection if required, all complete and ready to operate and as shown on the contract drawings.

4.02 OPERATING CONDITIONS

Included in this section shall be all pertinent data as to design conditions for which the pumping plant will be capable of handling. Included shall be the following:

	<u>Present</u>	<u>Future</u>	<u>Units</u>
A. Capacity			GPM
B. Max. Static Head			FEET
C. Min. Static Head			FEET
D. Total Dynamic Head			FEET
E. Shut-Off Head			FEET
F. Min. Efficiency			%
G. Min. Motor Size			HP
H. Operating Speed			RPM
I. Min. Solids Capacity			INCHES
J. Min. Discharge Size			INCHES

Also included should be an appropriate wet well program for the initial control period and the future control period similar to the following:

WET WELL PROGRAM (INITIAL)

LEVEL RISING

ELEV. IN LEAD LAG  
WET WELL PUMP PUMP

LEVEL FALLING

ELEV. IN LEAD LAG  
WET WELL PUMP PUMP

(LOW SANITARY SEWER)  
 (LOW SANITARY SEWER)

HIGH SANITARY SEWER ALARM

WET WELL PROGRAM (FUTURE)

LEVEL RISING  
ELEV. IN LEAD LAG  
WET WELL PUMP PUMP

LEVEL FALLING  
ELEV. IN LEADLAG  
WET WELL PUMP PUMP

(LOW SANITARY SEWER)

(LOW SANITARY SEWER)

HIGH SANITARY SEWER ALARM

4.03 MISCELLANEOUS SECTION

Following the general description and operating condition section should follow appropriate section on all equipment proposed, including:

1. Controls
2. Station Construction
3. Station Painting, Inside and Out
4. Spare Parts to be Included
5. Electrical Wiring
6. Water and Electrical Service
7. Sewage Pumps
8. Motors
9. Ventilation System
10. Dehumidifier
11. Sump Pump
12. Station Piping
13. Lighting
14. Clean Up of Site
15. Wet Well Screening, Comminution, etc.
16. Emergency Generating Equipment

#### 4.04 FIELD TESTS

Upon completion of the field installation, a field test shall be performed utilizing utility company water, and a check made to determine that the pump performance conforms with the pump characteristics curve for as long an operating period as is deemed necessary by the engineer. Pumps shall operate quietly, without vibrating, without motor overload, and without overheating of bearings.

## V. STANDARDS CONSTRUCTION DETAILS

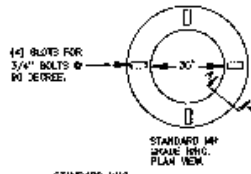

CONCRETE NOTES:  
 A-CONCRETE IS REQUIRED TO OBTAIN A STRENGTH OF 4000 PSI IN 28 DAYS.  
 B-DESIGN MEETS REQUIREMENTS OF A.S.T.M. STANDARD C-75.  
 C-WEIGHT OF ONE PIECE 30" DIA. - 300 LBS.

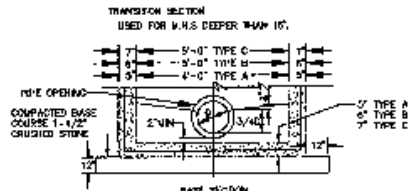
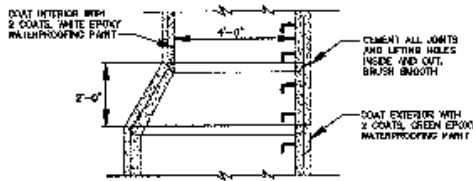
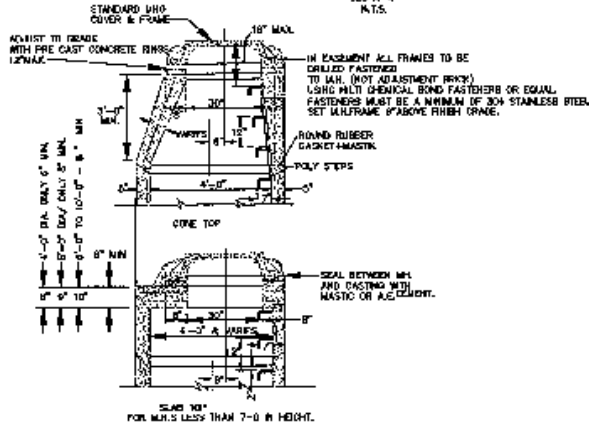
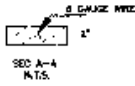

PLATE V-1

**SANITARY SEWER SYSTEM  
 STANDARD CONSTRUCTION DETAILS  
 BARNEGAT TOWNSHIP  
 OCEAN COUNTY NEW JERSEY**

## MANHOLE NOTES

### GENERAL

1. EXTERIOR SURFACES SHALL BE PAINTED WITH TWO COATS OF GREEN EPOXY FINISH.
2. INTERIOR SURFACES SHALL BE PAINTED WITH TWO COATS OF WHITE EPOXY FINISH.
3. ALL CONSTRUCTION SHALL MEET STANDARD SPECIFICATIONS; THE LATEST REVISIONS.
4. ALL CONSTRUCTION SHALL BE IN ACCORDANCE WITH THE LATEST O.S.H.A. STANDARDS WHERE POSSIBLE.

### PRE CAST CONCRETE MANHOLES (ASTM C-478)

1. TYPE "B" FOR SEWERS 24" TO 33" DIA. AND TYPE "C" FOR 36" TO 42" DIA.
2. WHERE TYPE "B" AND TYPE "C" BASES ARE USED, A TAPER SECTION CONNECTING BASE SECTION AND RISER SHALL BE REQUIRED AND SHALL HAVE A THICKNESS AS SHOWN. THE BASE SECTION AND RISER ALLOW FOR AT LEAST 6 FOOT MIN. VERTICAL CLEARANCE, WHERE POSSIBLE.

### MANHOLE STEPS

1. MANHOLE STEPS SHOULD BE MADE OF POLYPROPYLENE WITH POST FABRICATED FUSION-BONDED EPOXY COATED 1/2 INCH DEFORMED STEEL BAR.
2. THE PORTION TO BE EMBEDDED IN THE MANHOLE SHALL BE IN ACCORDANCE WITH THE LATEST O.S.H.A. STANDARD
3. SHOP DRAWINGS MUST BE SUBMITTED FOR ALL DETAILS.

### WORK AT EXISTING MANHOLES

1. AT THE DIRECTION OF THE ENGINEER, THE CONTRACTOR SHALL MACHINE CORE INTO THE MANHOLE AND COMPLETE A CONNECTION USING A SUITABLE MODULAR INTERLOCKING EPDM WITH STAINLESS STEEL HARDWARE WATERTIGHT SEAL, AS REQUIRED.
2. THE CONTRACTOR SHALL NOT INTERFERE WITH EXISTING SEWAGE SERVICE DURING THE PERIOD OF CONSTRUCTION AND SHALL TAKE ALL NECESSARY PRECAUTIONS TO KEEP DEBRIS OUT OF THE MANHOLES.

NOTE: WHERE SEWAGE FORCE MAINS DISCHARGE INTO MANHOLES OR MANHOLE PROPOSED AS A SEWAGE WET WELL CORROSION PROTECTION IS REQUIRED IN THE FORM OF SEMI RIGID P.V.C. SUCH AS MANUFACTURED BY ATLANTIC PRE CAST CONCRETE DURAPLATE LINER .  
THE SEMI-RIGID LINER SHALL EXTEND FROM THE BOTTOM OF THE MANHOLE ON UP TO THE BOTTOM OF THE MANHOLE FRAME.  
THE LINER SHALL EXTEND THROUGH THE ADJUSTMENT GRADE RING AND BE TELESCOPIC HERE.  
THERE SHALL BE BITUMASTIC SEALS WHERE THE MANHOLE FRAME SITS ON TOP THE P.V.C. FLANGE AND BELOW THE ADJUSTMENT RINGS.

**PLATE V-2**

**SANITARY SEWER SYSTEM  
STANDARD CONSTRUCTION DETAILS  
BARNEGAT TOWNSHIP  
OCEAN COUNTY NEW JERSEY**

STAINLESS STEEL CAP  
SCREWS (6) REQUIRED  
FOR WATERTIGHT MH.

WT. OF COVER = 186 lb.  
WT. OF FRAME = 312 lbs.

NON-PENETRATING  
PICK HOLES (2)

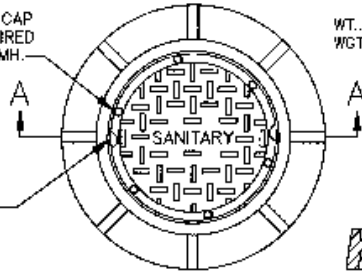

PLAN



LOCKING DEVICE  
SECTION

FLAT RUBBER  
GASKET ALL  
AROUND FOR  
WATERTIGHT M.H.

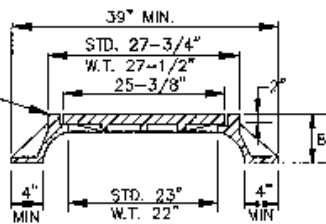

SECTION A-A

STANDARD OR WATERTIGHT MANHOLE  
FRAME AND COVER

NOT TO SCALE

NOTE:

- A--IN EASEMENT, FLOOD PLAIN OR REMOTE AREAS  
LOCKING DEVICES WILL BE REQUIRED.
- B--ALL CASTING MUST BE MARKED, ENABLING HOLES  
TO LINE UP.

**PLATE V-3**

**SANITARY SEWER SYSTEM  
STANDARD CONSTRUCTION DETAILS  
BARNEGAT TOWNSHIP  
OCEAN COUNTY NEW JERSEY**



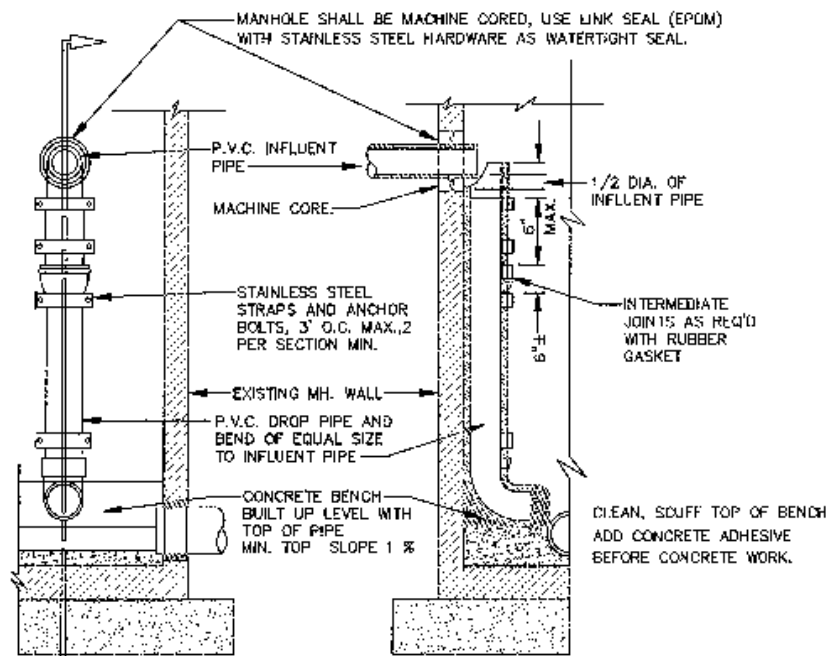

ELEVATION

SECTION SIDE VIEW.

MATCH HEIGHT OF BENCH BOTH SIDES OF MAIN.

**INSIDE DROP CONNECTION  
FOR EXISTING MANHOLE**

NOT TO SCALE

**PLATE V-4**

**SANITARY SEWER SYSTEM  
STANDARD CONSTRUCTION DETAILS  
BARNEGAT TOWNSHIP  
OCEAN COUNTY NEW JERSEY**

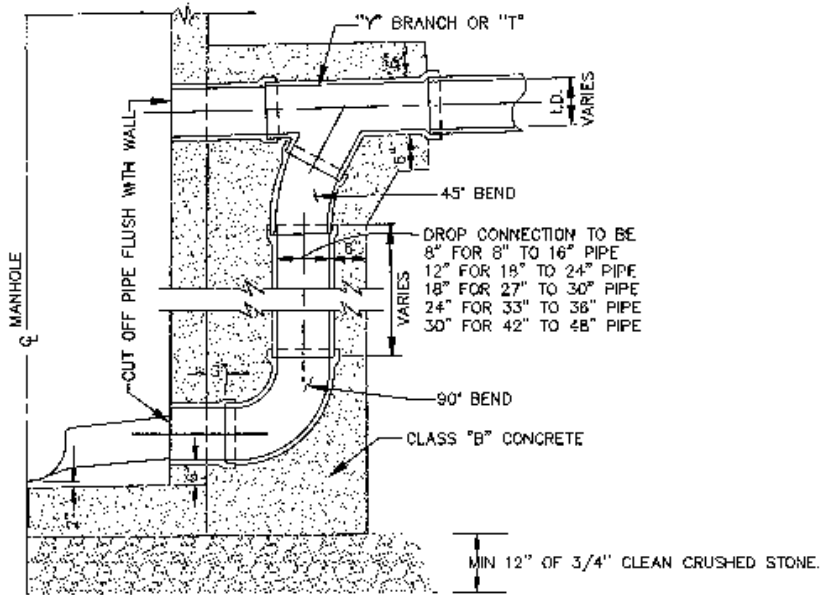

SECTION  
TYPICAL DROP MANHOLE  
 NOT TO SCALE

1. ALL TRENCHES AND EXCAVATIONS SHALL FOLLOW OSHA REGULATIONS (54FR45894) TO PROVIDE FOR THE PROTECTION OF PERSONNEL IN OR NEAR AN EXCAVATION.
2. SHOP DRAWING AND REINFORCING IS REQUIRED (ALSO DOWELS INTO M.H. IS REQUIRED IN CASE OF CAST IN PLACE.)

**PLATE V-5**

**SANITARY SEWER SYSTEM  
 STANDARD CONSTRUCTION DETAILS  
 BARNEGAT TOWNSHIP  
 OCEAN COUNTY NEW JERSEY**

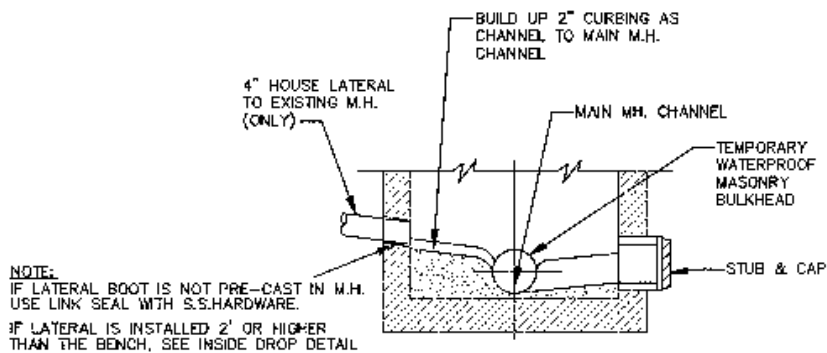

HOUSE LATERAL AND STUB  
AT MANHOLES

NOT TO SCALE

PLATE V-6

**SANITARY SEWER SYSTEM  
 STANDARD CONSTRUCTION DETAILS  
 BARNEGAT TOWNSHIP  
 OCEAN COUNTY NEW JERSEY**

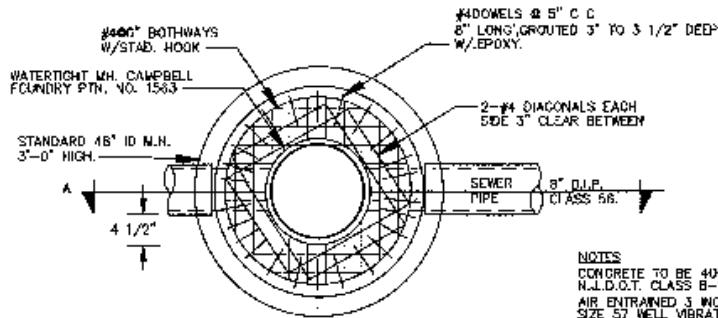

**PLAN VIEW**

**NOTES**  
 CONCRETE TO BE 4000 PSI  
 N.L.D.O.T. CLASS B-1  
 AIR ENTRAINED 3 INCHES SLUMP  
 SIZE 57 WELL VIBRATED  
 REINFORCING STEEL TO BE GRADE 60

**EXISTING**  
 CONCRETE SURFACE TO BE :  
 RUBBED WITH CARBORUNDUM  
 BRICK TO REMOVE SURFACE  
 DRESSING TO SOUND CONCRETE

CONCRETE TO BE WET-SURFACE  
 DRY WHEN NEW CONCRETE TOP  
 IS PLACED AND VIBRATED.

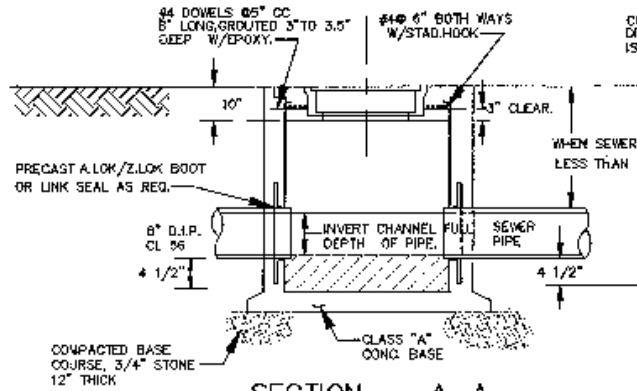

**SECTION A-A  
 SHALLOW MANHOLE**

NOT TO SCALE

**PLATE V-7**

**SANITARY SEWER SYSTEM  
 STANDARD CONSTRUCTION DETAILS  
 BARNEGAT TOWNSHIP  
 OCEAN COUNTY NEW JERSEY**

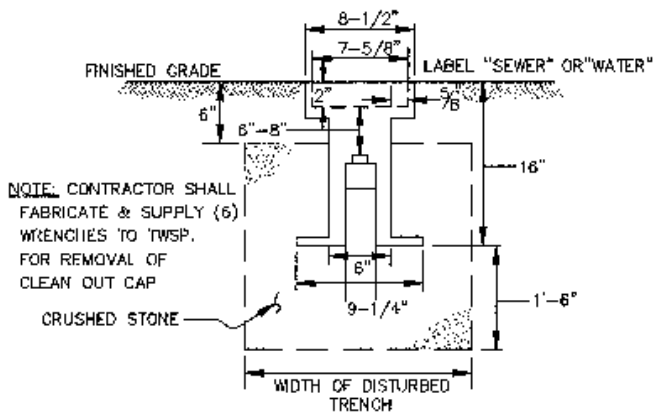

NOTE: CONTRACTOR SHALL  
 FABRICATE & SUPPLY (6)  
 WRENCHES TO TWSP.  
 FOR REMOVAL OF  
 CLEAN OUT CAP

**CLEAN OUT PROTECTION BOX DETAIL**

NOT TO SCALE

**PLATE V-8**

**SANITARY SEWER SYSTEM  
 STANDARD CONSTRUCTION DETAILS  
 BARNEGAT TOWNSHIP  
 OCEAN COUNTY NEW JERSEY**

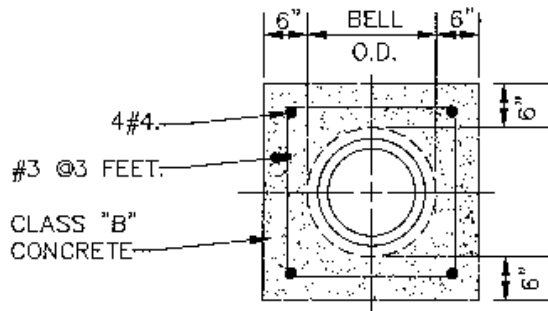

NOTE:

CONCRETE ENCASEMENT  
REQUIRED WHERE THERE IS  
8" OR LESS CLEARANCE  
BETWEEN PIPE CROSSINGS

PIPE ENCASED  
IN CONCRETE

NOT TO SCALE

PLATE V-9

**SANITARY SEWER SYSTEM  
STANDARD CONSTRUCTION DETAILS  
BARNEGAT TOWNSHIP  
OCEAN COUNTY NEW JERSEY**

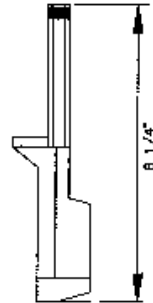
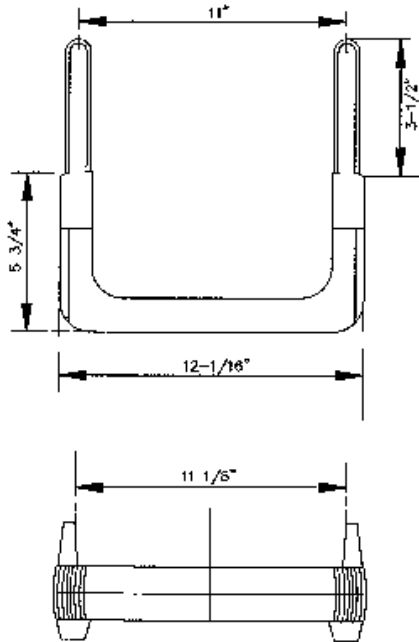

NOTE:  
POST FABRICATION, FUSION - BONDED,  
EPOXY COATED 1/2 HIGH DEFORMED STEEL BAR

POLYPROPYLENE MANHOLE STEP

NOT TO SCALE

PLATE V-10

**SANITARY SEWER SYSTEM  
STANDARD CONSTRUCTION DETAILS  
BARNEGAT TOWNSHIP  
OCEAN COUNTY NEW JERSEY**

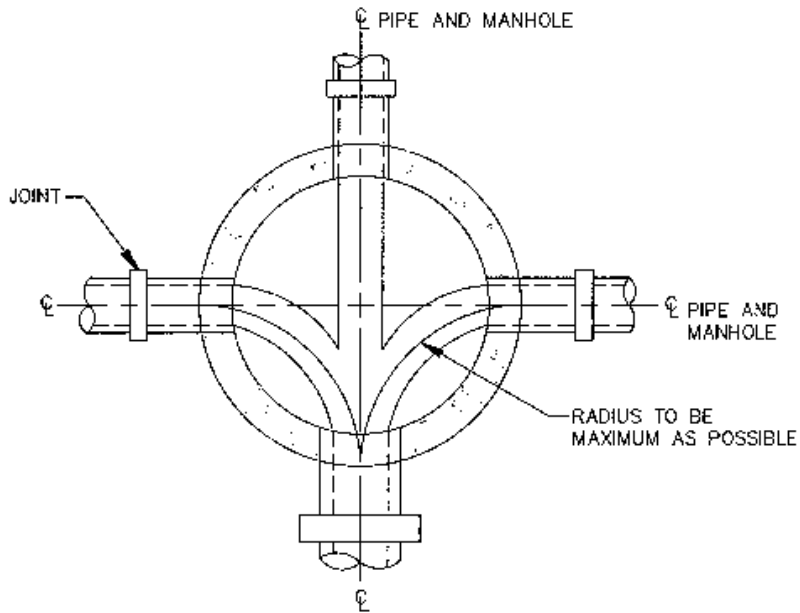

TYPICAL CHANNELING  
OF MANHOLE BOTTOM

NOT TO SCALE

PLATE V-11

**SANITARY SEWER SYSTEM  
STANDARD CONSTRUCTION DETAILS  
BARNEGAT TOWNSHIP  
OCEAN COUNTY NEW JERSEY**



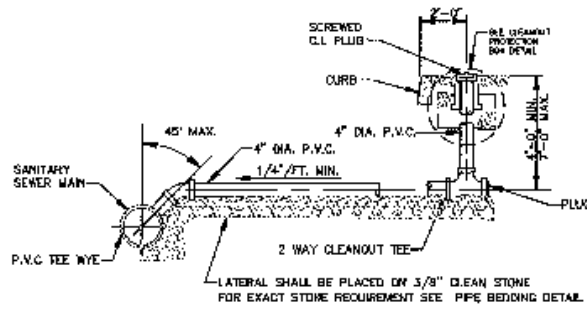

**ELEVATION**  
(SADDLE INSTALLATION SIMILAR)

NOTE:  
WHEN CUTTING NEW 4\"/>

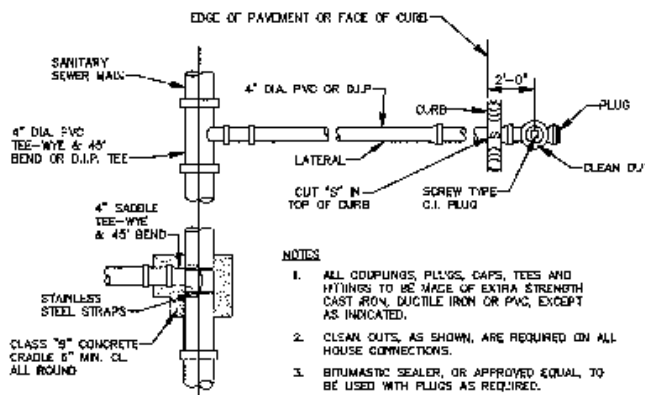

**NOTES**

1. ALL COUPLINGS, PLUGS, CAPS, TEES AND FITTINGS TO BE MADE OF EXTRA STRENGTH CAST IRON, DUCTILE IRON OR PVC, EXCEPT AS INDICATED.
2. CLEAN OUTS, AS SHOWN, ARE REQUIRED ON ALL HOUSE CONNECTIONS.
3. BITUMASTIC SEALER, OR APPROVED EQUAL, TO BE USED WITH PLUGS AS REQUIRED.
4. 8 GAUGE TRACER WIRE TO TERMINATE AT CLEANOUT PROTECTION BOX.

**PLAN**  
**TYPICAL 4 INCH HOUSE**  
**CONNECTION INSTALLATION**  
NOT TO SCALE

**PLATE V-12**

**SANITARY SEWER SYSTEM**  
**STANDARD CONSTRUCTION DETAILS**  
**BARNEGAT TOWNSHIP**  
**OCEAN COUNTY NEW JERSEY**

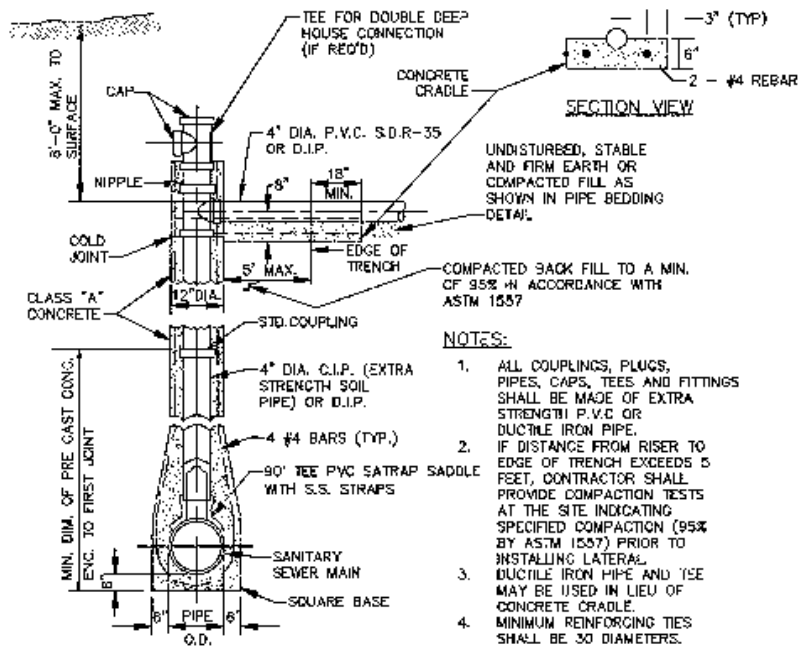

**NOTES:**

1. ALL COUPLINGS, PLUGS, PIPES, CAPS, TEES AND FITTINGS SHALL BE MADE OF EXTRA STRENGTH P.V.C. OR DUCTILE IRON PIPE.
2. IF DISTANCE FROM RISER TO EDGE OF TRENCH EXCEEDS 5 FEET, CONTRACTOR SHALL PROVIDE COMPACTION TESTS AT THE SITE INDICATING SPECIFIED COMPACTION (95% BY ASTM 1557) PRIOR TO INSTALLING LATERALS.
3. DUCTILE IRON PIPE AND TEE MAY BE USED IN LIEU OF CONCRETE CRADLE.
4. MINIMUM REINFORCING TIES SHALL BE 30 DIAMETERS.
5. WHEN USING ULTRA RIB PVC, ULTRA RIB TEES MUST BE USED.
6. SUBMIT SHOP DRAWING FOR APPROVAL OF SIMILAR PRECAST SECTIONS

**TYPICAL 4 INCH  
DEEP HOUSE CONNECTION**  
NOT TO SCALE

**PLATE V-13**

**SANITARY SEWER SYSTEM  
STANDARD CONSTRUCTION DETAILS  
BARNEGAT TOWNSHIP  
OCEAN COUNTY NEW JERSEY**

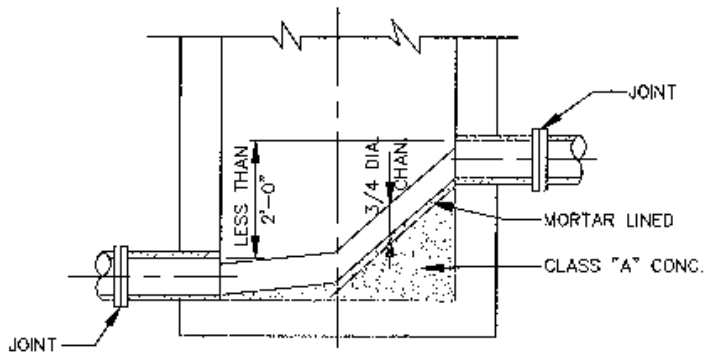

**NOTE:** MANHOLE CHUTE IS TO BE USED WHERE DIFFERENCE IN CROWN ELEVATIONS BETWEEN INCOMING AND OUTGOING PIPE IS LESS THAN 2'-0". IF THE DIFFERENCE IS 2'-0" OR GREATER, THEN DROP CONNECTION SHALL BE MADE AS SHOWN IN DETAIL.

**MANHOLE CHUTE**

NOT TO SCALE

**PLATE V-14**

**SANITARY SEWER SYSTEM  
STANDARD CONSTRUCTION DETAILS  
BARNEGAT TOWNSHIP  
OCEAN COUNTY NEW JERSEY**

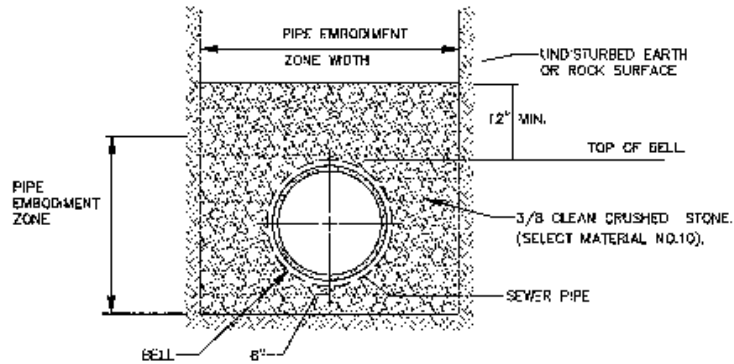

**PVC PIPE  
ORDINARY BEDDING**

NOT TO SCALE

**PLATE V-15**

**SANITARY SEWER SYSTEM  
STANDARD CONSTRUCTION DETAILS  
BARNEGAT TOWNSHIP  
OCEAN COUNTY NEW JERSEY**

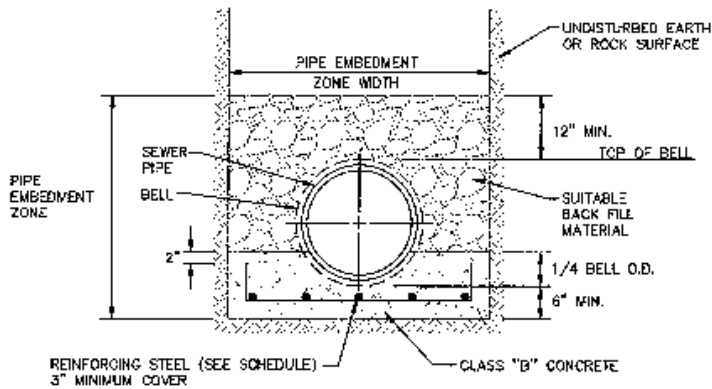

REINFORCED CONCRETE  
CLASS "A" MODIFIED  
CONCRETE CRADLE BEDDING  
 NOT TO SCALE

**PLATE V-16**

**SANITARY SEWER SYSTEM**  
**STANDARD CONSTRUCTION DETAILS**  
**BARNEGAT TOWNSHIP**  
**OCEAN COUNTY NEW JERSEY**

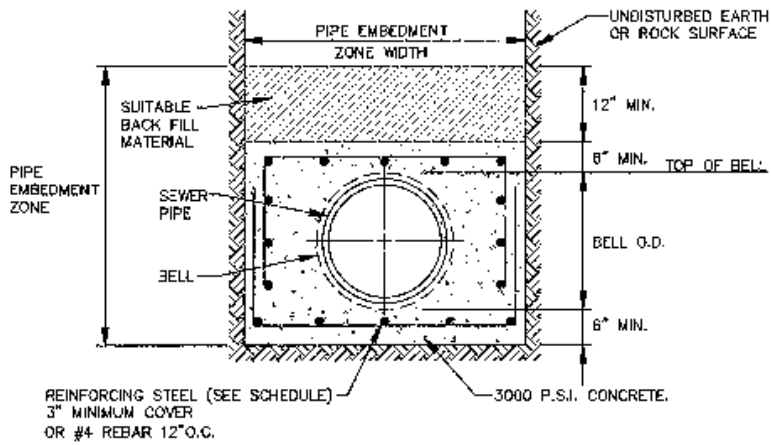

REINFORCED CONCRETE  
CLASS "A-1" MODIFIED  
CONCRETE CRADLE BEDDING

NOT TO SCALE

PLATE V-17

**SANITARY SEWER SYSTEM  
 STANDARD CONSTRUCTION DETAILS  
 BARNEGAT TOWNSHIP  
 OCEAN COUNTY NEW JERSEY**

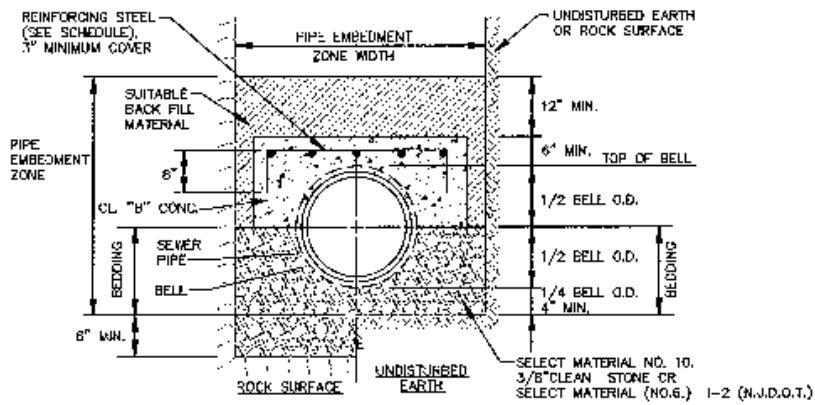

REINFORCED CONCRETE  
CLASS "A-2" MODIFIED  
CONCRETE ARCH BEDDING  
 NOT TO SCALE

**PLATE V-18**

**SANITARY SEWER SYSTEM  
 STANDARD CONSTRUCTION DETAILS  
 BARNEGAT TOWNSHIP  
 OCEAN COUNTY NEW JERSEY**

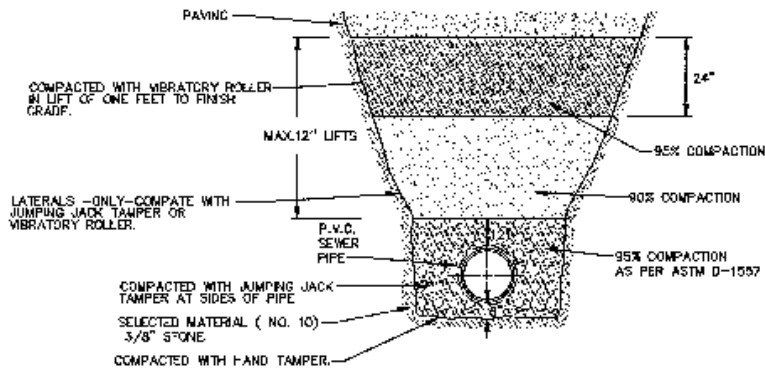

**GENERAL NOTES**

1. SUITABLE BACK FILL MATERIAL SHALL BE SELECT MATERIAL 1-2 (N.J.D.O.T.) WHEN ON SITE SUITABLE MATERIAL IS NOT AVAILABLE.
2. CHOKED CRUSHED STONE MAY BE SUBSTITUTED FOR SELECT MATERIAL (NO. 8) 1-2 (N.J.D.O.T.) AS APPROVED BY THE ENGINEER. CHOKED CRUSHED STONE SHALL BE CRUSHED STONE (COARSE AGGREGATE NO. 57 AS PER N.J.D.O.T. SPECIFICATIONS) CHOKED WITH SAND WHICH WILL PASS A NO. 10 SIEVE AND BE RETAINED ON A NO. 200 SIEVE.
3. ALL TRENCHES AND EXCAVATION TO BE GIVEN THE STEEPEST SLOPE PRACTICABLE.
4. COMPACTION SHALL BE PERFORMED IN MAXIMUM 12" LIFTS UNLESS ANOTHER COMPACTION EFFORT IS PROVED BY A SOIL ENGINEER.
5. COMPACTION BACK FILL SHALL BE AS A MINIMUM 90% OF MAXIMUM DRY DENSITY OF SOIL AS DETERMINED BY ASTM D-1557.
6. COMPACTION OF TOP 2 FEET OF (SURFACE ZONE) UNDER AREAS TO BE PAVED SHALL ACHIEVE AS A MINIMUM 95% OF MAXIMUM DRY DENSITY AS DETERMINED BY ASTM D-1557.
7. LIMITS OF TRENCH TO BE CUT TO A NEAT EDGE AND SEALED WITH EMULSIFIED ASPHALT. BE SPRINKLED TO PREVENT PICK UP BY TRAFFIC.
- 8- ALL TRENCHES AND EXCAVATIONS SHALL FOLLOW OSHA REGULATIONS (54FR45854) TO PROVIDE FOR THE PROTECTION OF PERSONNEL IN OR NEAR AN EXCAVATION.

**REQUIRED BACKFILL/COMPACTION**

NOT TO SCALE

**PLATE V-19**

**SANITARY SEWER SYSTEM  
STANDARD CONSTRUCTION DETAILS  
BARNEGAT TOWNSHIP  
OCEAN COUNTY NEW JERSEY**



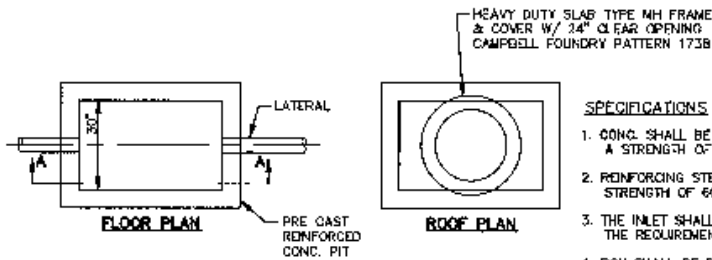
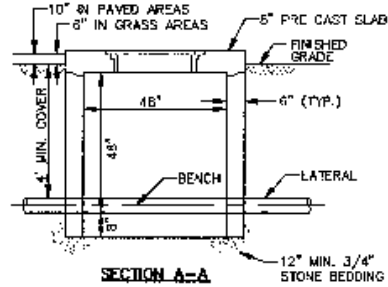

**SPECIFICATIONS**

1. CONC. SHALL BE DESIGNED TO OBTAIN A STRENGTH OF 4000 psi IN 28 DAYS
2. REINFORCING STEEL TO HAVE A YIELD STRENGTH OF 60,000 psi
3. THE INLET SHALL BE DESIGNED TO MEET THE REQUIREMENTS OF ASTM SPEC C-193
4. BOX SHALL BE DESIGN TO CARRY H2O LOADING

**GREASE MONITORING PIT DETAIL**

NOT TO SCALE

**PLATE V-20**

**SANITARY SEWER SYSTEM  
STANDARD CONSTRUCTION DETAILS  
BARNEGAT TOWNSHIP  
OCEAN COUNTY NEW JERSEY**

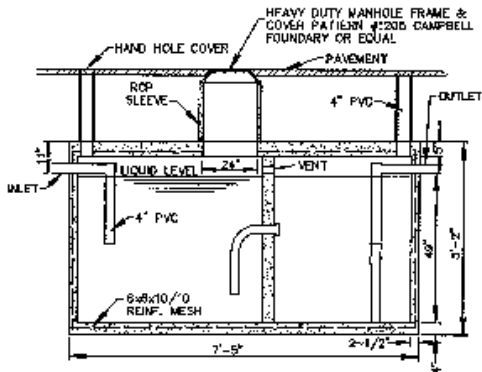

**SPECIFICATIONS**

1. CONC. SHALL BE DESIGNED TO OBTAIN A STRENGTH OF 4000 psi IN 28 DAYS
2. REINFORCING STEEL TO HAVE A YIELD STRENGTH OF 80,000 psi.
3. THE INLET SHALL BE DESIGNED TO MEET THE REQUIREMENTS OF ASTM SPEC C-193
4. STRUCTURE SHALL BE DESIGN TO CARRY H2O LOADING, WHERE NECESSARY.
5. STRUCTURE TO BE PLACED ON A BED 12" THICK, 3/4" CRUSHED BLUE STONE.

**1,000 GAL. GREASE TRAP**  
NOT TO SCALE

**PLATE V-21**

**SANITARY SEWER SYSTEM  
STANDARD CONSTRUCTION DETAILS  
BARNEGAT TOWNSHIP  
OCEAN COUNTY NEW JERSEY**

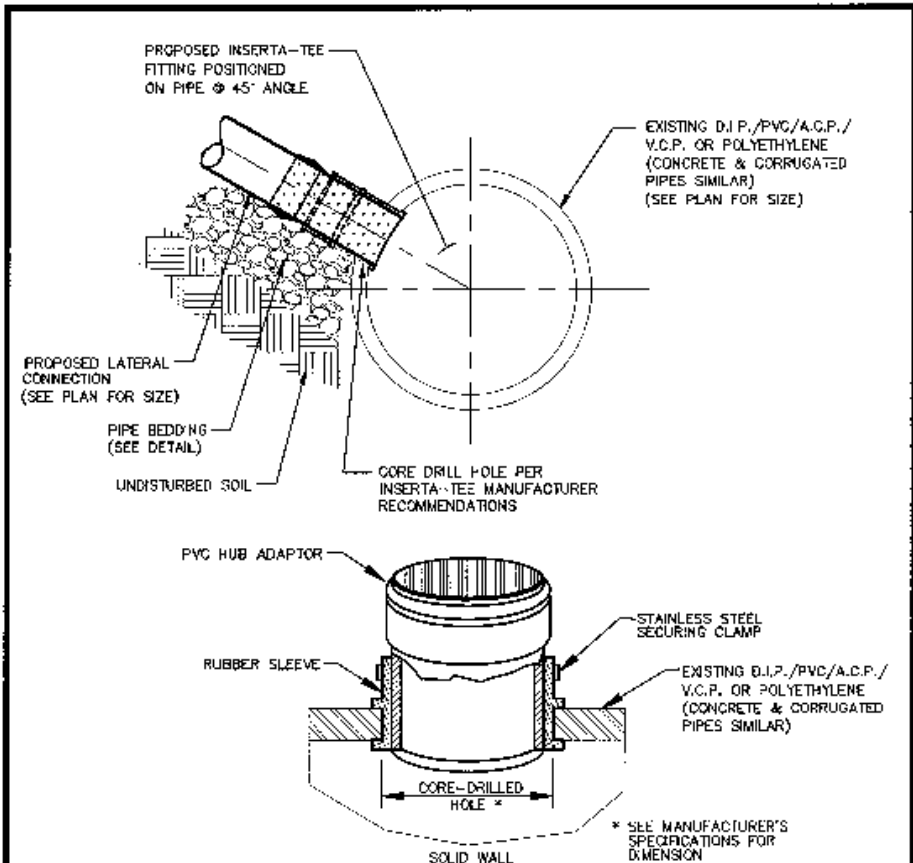

**NOTES:**

1. RUBBER SLEEVE SHALL CONFORM TO ASTM-C443.
2. SECURING CLAMP SHALL BE S.S.#301 (BEND AND HOUSING), S.S.#305 (SCREW)
3. HUB ADAPTOR SHALL BE PVC PER ASTM D3034 (SOR SAME AS LATERAL PIPE).

**DETAIL OF INSERTA TEE CONNECTION**

N.T.S.

**PLATE V-22**

**SANITARY SEWER SYSTEM  
STANDARD CONSTRUCTION DETAILS  
BARNEGAT TOWNSHIP  
OCEAN COUNTY NEW JERSEY**

## VI. STANDARDS FOR ACCEPTABLE WASTES

## REQUIREMENTS OF WASTEWATER DISCHARGED INTO THE SEWERAGE SYSTEM

Discharges into the Township system shall be in accordance with the Sewer Use Rules and Regulations of the Ocean County Utilities Authority, the Federal Pollution Control Act Amendments of 1972, the Clean Water Act of 1977, and any subsequent amendments or applicable legislation.

Wastewater delivered into the facilities of the Township shall not:

1. Be of such a strength quantity or quality as to impair the operation or lower the efficiency of the processes of wastewater treatment and sludge handling and disposal, such as excessive biochemical oxygen demand, suspended solids, or chlorine demand, substances inhibitory to the biological processes such as excessive heavy metals, phenols and their derivatives, strong oxidizing agents or strong reducing agents.
2. Be of such a nature as to prevent the effluent from the plant from meeting all present or future requirements of any governing agency having jurisdiction over the receiving waters, such as standards for biochemical oxygen demand, chemical oxygen demand, suspended solids, color, heavy metals, dissolved oxygen in both effluent and receiving waters, bacterial counts, etc.
3. Contain any gasoline, benzene, naphtha, fuel oil, or other flammable or explosive liquid, solid, or gas which by reason of its nature or quality may cause fire or explosion or which, in any other way, may be injurious to personnel or facilities within the sewerage system.
4. Be of such a nature as to form noxious or malodorous gasses or substances which either singularly or through interaction with other wastes or substances found in wastewater treatment processes create a public nuisance, hazard to life, or prevent entry into any portion of the sewerage system for operational duties, maintenance or repair.
5. Be of such a nature as to, in any manner impair the strength, function, or durability of any portion of the sewerage facilities, such as compounds producing hydrogen sulfide or any other substances corrosive to any measurable degree to any materials used in the trunk system
6. Be of such a nature and in such a quantity as to impair the hydraulic capacity of such facilities, normal and reasonable wear and usage excepted; such wastes would include uncomminuted garbage, animal guts, tissues or blood, paunch manure, bone, hair, hides, fleshings, entrails, feathers, sand, cinders, ashes, spent lime, stone or marble dust, metal, glass, straw, shavings, grass clippings, rags, spent grain, waste paper, wood, plastic, gas, tar, asphalt residues, etc.
7. Include any radioactive substance.

8. Include any garbage other than that received directly into public sewers from residences.
9. Have a pH value lower than 5.5 or higher than 9.5.
10. Have a temperature higher than one hundred four degrees Fahrenheit (104 degrees F).
11. Have a flash point lower than 235°F as determined by the Tagliabue (tag) closed cup methods.
12. Contain fats, wax, grease, or oils, whether emulsified or not, in excess of one hundred milligrams per liter (100 mg/l) or contain substances which may solidify or become viscous at temperatures between thirty two (32 degrees F) and one hundred fifty (150 degrees F) degrees Fahrenheit.
13. Be discharged by tank trucks into manholes or appurtenances of the sewerage system without written consent of the Township.
14. Be delivered in a "slug" manner by which is meant that the normal hydraulic or organic loading shall not be exceeded by more than a 5.0 factor of average 24 hour concentration for any period exceeding fifteen (15) minutes.

All connections to the sewerage system and local collection sewerage system for garages or other buildings in which grease or oil is handled must be equipped with a suitable mechanism to trap and collect all such oils and greases.

The township reserves the right to make whatsoever changes in its discharge requirements as may be necessary for the operation, maintenance, and protection of its sewerage system, for meeting revised standards of influent or effluent quality of regulatory agencies having jurisdiction in this regard, or for any other reason the Township deems is desirable or necessary for performing its stated functions.

VII. APPLICATION AND PERMIT FORMS

DEED OF EASEMENT AND RIGHT OF WAY

THIS INDENTURE made this \_\_\_\_\_ day of \_\_\_\_\_ 20\_\_ by and between:

and

TOWNSHIP OF BARNEGAT, a body public, corporate and politic, of the County of Ocean, State of New Jersey, hereinafter referred to as "GRANTEE".

W I T N E S E T H

The Grantor, in consideration of the sum of ONE DOLLAR (\$1.00), and other good and valuable consideration, the receipt of which is hereby acknowledged, does hereby give, grant and convey unto the Grantee, its successors and assigns forever, an easement and a free uninterrupted and unobstructed right of way, under, across and over the property of the grantor, situated in the Township of Barnegat, County of Ocean, and State of New Jersey, which easement is more particularly described on Schedule A, which is attached hereto and made a part hereof, as though set forth at length.

For the purpose of installing, laying, operating, maintaining, inspecting, removing, repairing, replacing, relaying and adding to from time to time, pipe or pipes with necessary fittings, appurtenances and attached facilities, included services and connections for water mains.

Together with the right to the grantee, its successors and assigns, to enter in and upon the premises described above with men and machines, vehicles and materials, at any and all times, for the purpose of maintaining, repairing, renewing or adding to the aforesaid water mains and appurtenances, and for doing anything necessary, useful or convenient, for the enjoyment of the easement herein granted.

To have and to hold the above granted easement and right of way unto the said grantee, its successors and assigns forever.

The grantee agrees by the acceptance of the Deed of Easement and Right-of-Way that upon any opening made in connection with any of the purposes of this easement and right-of-way, said opening shall be backfilled and resurfaced to as nearly as possible the same conditions as existed when said opening was made, all such work to be done at the expense of the grantee.

It is understood and agreed that the grantor is not to convey title to the grantee to that portion of the premises described in Schedule A, but an easement.

And the said Grantor and Grantee do further covenant and agree as follows:



1. That the Grantor is seized of the easement and right of way herein granted, and has good right to convey title to the same and does warrant and agree to defend the Grantee at his own cost and expense any and all claims relative to said title.
2. That the Grantee shall quietly enjoy the easement and right-of-way granted herein.
3. All shrubs, trees, driveways and other appurtenances disturbed by Grantee shall be restored to their original condition as reasonably possible. This provision shall survive the closing of title.
4. The Grantor hereby transfers any title that the Grantor may have to the underground Sanitary Sewer system, which he constructed in the aforesaid easement to the Township of Barnegat.

IN WITNESS WHEREOF, the Grantor has hereunto set its hand and seal the day and year first above written.

\_\_\_\_\_ By \_\_\_\_\_

STATE OF NEW JERSEY)

: S.S.:

COUNTY OF OCEAN

BE IT REMEMBERED, that on this \_\_\_\_\_ day of \_\_\_\_\_, 20\_\_\_\_ before me, the subscriber, an attorney-at-law, personally appeared, who, being by me duly sworn on oath, deposes and makes proof to my satisfaction, that \_\_\_\_\_ is the secretary of the corporation named in the within Instrument, that \_\_\_\_\_ is the president of said corporation; that the execution, as well as the making of this instrument, has been duly authorized by a proper resolution of the Board of Directors of said corporation; that deponent well knows the corporate seal of said corporation; and that the seal affixed to said instrument is the proper corporate seal and was thereto affixed and said instrument signed and delivered by said president as and for the voluntary act and deed of said corporation in presence of deponent, who thereupon subscribed her name thereto as attesting witness.

Sworn to and subscribed before me the date aforesaid \_\_\_\_\_  
\_\_\_\_\_.

Review Application No. \_\_\_\_\_

TOWNSHIP OF BARNEGAT

Application for Review of  
Preliminary Plans  
For  
Sanitary Sewer System Facilities

This Application must be filed, in duplicate, with the Township Clerk and shall be accompanied by an application fee determined in accordance with the Fee Schedule.

Application is hereby made for review and approval of preliminary plans for the construction of sanitary sewer system facilities.

1. Applicant's Name: \_\_\_\_\_  
\_\_\_\_\_

Address: \_\_\_\_\_ Phone: \_\_\_\_\_  
\_\_\_\_\_  
\_\_\_\_\_

2. Name and Address of Present Owner if Other than above: \_\_\_\_\_  
\_\_\_\_\_  
\_\_\_\_\_

3. Location of Proposed Construction:  
Street: \_\_\_\_\_ Tax Map Block No(s) \_\_\_\_\_

4. Number of Proposed Connections to be Served: \_\_\_\_\_  
Estimated Average Daily Usage or Flow per Connection (in Gallons per Day): \_\_\_\_\_  
\_\_\_\_\_

5. Name and Profession of Person Designing Plans: \_\_\_\_\_  
Name: \_\_\_\_\_ Profession: \_\_\_\_\_  
Address: \_\_\_\_\_ Phone \_\_\_\_\_  
\_\_\_\_\_

6. Describe your proposal for sanitary sewer supply: \_\_\_\_\_  
\_\_\_\_\_  
\_\_\_\_\_

7. List Plans and Other Supporting Data Accompanying this application: \_\_\_\_\_  
\_\_\_\_\_  
\_\_\_\_\_  
\_\_\_\_\_

\_\_\_\_\_  
Signature of Applicant

\_\_\_\_\_  
Date

MAKE ALL CHECKS PAYABLE TO: TOWNSHIP OF BARNEGAT

*For Official Use Only*

Date Received and Fee Collected by Township Clerk:

Date: \_\_\_\_\_ Fee: \_\_\_\_\_

Engineer's Review Remarks: \_\_\_\_\_  
\_\_\_\_\_  
\_\_\_\_\_  
\_\_\_\_\_

|

Review remarks: \_\_\_\_\_  
\_\_\_\_\_  
\_\_\_\_\_

Approved: \_\_\_\_\_ Disapproved: \_\_\_\_\_

Recommendations: \_\_\_\_\_  
\_\_\_\_\_  
\_\_\_\_\_

Date: \_\_\_\_\_

Township Clerk: \_\_\_\_\_

Review Application No. \_\_\_\_\_

TOWNSHIP OF BARNEGAT

Application for Review of Final Plans  
For  
Sanitary Sewer System Facilities

This application must be filed, in duplicate, with the Township Clerk and shall be accompanied by application and inspection fees determined in accordance with the Fee Schedule.

Application is hereby made for review and approval of final plans for the construction of sanitary sewer system facilities.

1. Applicant's name: \_\_\_\_\_  
 Address: \_\_\_\_\_ Phone: \_\_\_\_\_  
 Name and address of present owner if other than above: \_\_\_\_\_  
 \_\_\_\_\_
2. Location of Proposed Construction: \_\_\_\_\_  
 Street: \_\_\_\_\_  
 Tax Map Block No(s). \_\_\_\_\_
3. Number of Proposed Units to be Served; \_\_\_\_\_
4. Name and Profession of person designing plans:  
 Name: \_\_\_\_\_ Profession: \_\_\_\_\_  
 Address: \_\_\_\_\_ Phone: \_\_\_\_\_  
 \_\_\_\_\_
5. Description of Use: \_\_\_\_\_  
 Commercial Units: \_\_\_\_\_  
 \_\_\_\_\_

Industrial Units: \_\_\_\_\_

\_\_\_\_\_

Residential Units: \_\_\_\_\_

6. Does applicant have title in order to convey by fee to the Township, easements to all areas showing sanitary sewer system facilities and all rights to the sanitary sewer system facilities: \_\_\_\_\_

\_\_\_\_\_

7. Describe proposed source of sanitary sewer supply: \_\_\_\_\_

\_\_\_\_\_

\_\_\_\_\_

8. List plans and other supporting data accompanying this application:

a) \_\_\_\_\_

b) \_\_\_\_\_

c) \_\_\_\_\_

d) \_\_\_\_\_

e) \_\_\_\_\_

f) \_\_\_\_\_

9. Preliminary Application No. \_\_\_\_\_

Date Approved: \_\_\_\_\_

10. Does the final plan follow exactly the preliminary plans approved by the Township; \_\_\_\_\_

If not, indicate changes \_\_\_\_\_

\_\_\_\_\_

\_\_\_\_\_

11. Date of filing final plan with Township Planning Board: \_\_\_\_\_

12. Calendar days required to complete the entire project, after approval is granted: \_\_\_\_\_

\_\_\_\_\_  
Signature of Applicant

\_\_\_\_\_  
Date

MAKE ALL CHECKS PAYABLE TO: TOWNSHIP OF BARNEGAT

*For official Use Only*

Date received and fee collected by Township Clerk:

Date: \_\_\_\_\_

Application Fee: \$ \_\_\_\_\_

Date: \_\_\_\_\_

Inspection Fee \$ \_\_\_\_\_  
(Cash, certified check)

Easements Received: \_\_\_\_\_

\_\_\_\_\_  
\_\_\_\_\_  
\_\_\_\_\_

Latest revision date on drawings: \_\_\_\_\_

Engineer's Review Remarks: \_\_\_\_\_

\_\_\_\_\_  
\_\_\_\_\_  
\_\_\_\_\_  
\_\_\_\_\_

REVIEW REMARKS: \_\_\_\_\_

---

---

Approved: \_\_\_\_\_ Disapproved: \_\_\_\_\_

Recommendations: \_\_\_\_\_

---

---

\_\_\_\_\_  
Township Clerk

\_\_\_\_\_  
Date



Application No. \_\_\_\_\_

TOWNSHIP OF BARNEGAT

Application for Certification of Completion  
For  
Sanitary Sewer System Facilities

- 1. Applicant's name: \_\_\_\_\_  
Address: \_\_\_\_\_ Phone \_\_\_\_\_
- 2. Name and address of present owner if other than above: \_\_\_\_\_  
\_\_\_\_\_
- 3. Final Application No.: \_\_\_\_\_  
Date of approval: \_\_\_\_\_
- 4. Dates of construction:  
Starting: \_\_\_\_\_ Finishing: \_\_\_\_\_
- 5. Have as-built plans for the construction been approved by the Township Engineers?  
YES NO
- 6. Have the sanitary sewer mains been tested and TV inspected (with the digital recordings and written reports submitted) by the Contractor, and witnessed/approved by the Township Engineers?  
YES NO
- 7. Have the legal documents been drawn up and received by the Township, transferring interest in the sanitary sewer system facilities to the Township?  
YES NO
- 8. Have connection fees and all other fees been paid by the Applicant?  
YES NO

\_\_\_\_\_  
Signature of Applicant

\_\_\_\_\_  
Date

*For Official Use Only*

Date received: \_\_\_\_\_

Township Engineer's Remarks: \_\_\_\_\_

\_\_\_\_\_  
\_\_\_\_\_

Date as-built plans received: \_\_\_\_\_

Date conveyance of facility received: \_\_\_\_\_

Action of the TOWNSHIP OF BARNEGAT

Remarks: \_\_\_\_\_

\_\_\_\_\_

Date connection fees received: \_\_\_\_\_

Action of the TOWNSHIP OF BARNEGAT

Remarks: \_\_\_\_\_

\_\_\_\_\_

Approved: \_\_\_\_\_ Disapproved: \_\_\_\_\_

Certificate of Completion granted: \_\_\_\_\_  
(date)

Township Clerk: \_\_\_\_\_

BILL OF SALE

KNOW ALL MEN BY THESE PRESENTS:

THAT \_\_\_\_\_ for and in consideration of the TOWNSHIP OF BARNEGAT, Barnegat Township, New Jersey granting to \_\_\_\_\_ for the installation of Sanitary Sewer mains. The aforesaid \_\_\_\_\_ does hereby convey and transfer all of its right, title and interest in and to said sanitary sewer mains and all the appurtenances connected thereto for the operation of said sanitary sewer mains to the aforesaid Township of Barnegat.

THE said \_\_\_\_\_ does hereby warrant and represent that all equipment, materials, and labor have been paid for in full.

TO have and to hold the same unto the Township of Barnegat forever; and \_\_\_\_\_ covenants and chattels unto the Township of Barnegat against all and every person or persons, except as otherwise herein stated.

ALL the terms, covenants and conditions herein contained shall be for and shall insure to the benefit of and shall bind the respective parties hereto, and their legal representatives, successors and assigns. In all references herein to any parties, persons, entities or corporations the use of any particular gender or the plural or singular number is intended to include the appropriate gender or number as the text of the within instrument may require.

IN WITNESS WHEREOF, \_\_\_\_\_ has caused this instrument to be signed by its proper corporate officers and its corporate seal to be affixed, the day of \_\_\_\_\_, 20\_\_\_\_.

RESOLUTION OF SALE

BE IT RESOLVED that the transaction herein referred to, being herewith approved \_\_\_\_\_, president and \_\_\_\_\_, secretary of this corporation be and they are hereby direct, authorized and empowered to execute, acknowledge and deliver such documents, instruments and papers and perform such acts as may be legally, properly and reasonably required or necessary for the purpose of \_\_\_\_\_

\_\_\_\_\_

\_\_\_\_\_

\_\_\_\_\_

I, \_\_\_\_\_ secretary of a corporation of \_\_\_\_\_ certify that the foregoing is a true copy of a Resolution as it appears in the records of the corporation and as was duly and legally adopted at a meeting of the Board of Directors of the corporation called for that purpose and held on \_\_\_\_\_ pursuant to and in accordance with the Certificate of Incorporation and By-laws thereof; that it has not been modified, amended or rescinded and is in full force and effect as of the date hereof.

Dated: \_\_\_\_\_

\_\_\_\_\_ President

Attest: \_\_\_\_\_

Secretary

CONTRACTOR'S AFFIDAVIT

STATE OF NEW JERSEY)

:SS.

COUNTY OF OCEAN

\_\_\_\_\_ of full age, being duly sworn, according to law upon his oath dispossesses and says that:

1. I am an officer of \_\_\_\_\_ a corporation of the State of \_\_\_\_\_, said corporation being the owner of the property designated in \_\_\_\_\_ attached hereto and made a part hereof.
2. I do hereby state and represent that all subcontractors and materialmen who have supplied any labor and/or material on the aforementioned property have been or are being paid in full in accordance with an agreement entered into between the above-mentioned corporation and the supplier or contract, and that no stop notice, mechanics' notice of intention and/or mechanics' lien or any other lien has been filed against the aforesaid premises, which would adversely affect the easement granted to the Township of Barnegat.

\_\_\_\_\_  
Signature/Date

Sworn to and subscribed to \_\_\_\_\_ before me this day of \_\_\_\_\_, 20\_\_\_\_\_.

CORPORATE RESOLUTION

At a special meeting held by \_\_\_\_\_, held at its principal office located at

\_\_\_\_\_, on \_\_\_\_\_, 20\_\_\_\_\_

\_\_\_\_\_, a majority of Directors were present at said meeting. Upon motion duly made, seconded and carried by unanimous consent, it was RESOLVED, that the Corporation grant to the Township of Barnegat a \_\_\_\_\_ easement on \_\_\_\_\_

\_\_\_\_\_ for a total price of \$1.00, and it was further RESOLVED, that the proper corporate officers are hereby authorized and empowered to execute any and all documents necessary to consummate the above transaction.

By: \_\_\_\_\_

I hereby certify that the above is a true copy of the Resolution duly adopted at a special meeting held by \_\_\_\_\_ on \_\_\_\_\_.

\_\_\_\_\_  
Secretary

INDIVIDUAL SANITARY SEWER SERVICE INSTALLATION  
Application No. \_\_\_\_\_

TO BE FILED IN DUPLICATE

TOWNSHIP OF BARNEGAT  
SANITARY SEWER SYSTEM

1. Premises to be connected \_\_\_\_\_  
(Street address)

\_\_\_\_\_ (Block) \_\_\_\_\_ (Lot)

2. Name and Address of Owner:

Name: \_\_\_\_\_

Address: \_\_\_\_\_

Phone: \_\_\_\_\_

It is understood and agreed that the applicant has elected to install a sanitary sewer service and that same will be installed at the sole expense of the applicant with no cost attaching to the Township. It is also agreed that the Township shall be the sole owner of the sanitary sewer service constructed. The applicant is responsible to obtain the necessary road opening permit for construction of said Sanitary Sewer service.

The applicant is to pay the required connection and inspection fees as stipulated in the FEE SCHEDULE.

CONNECTION FEE: \$ \_\_\_\_\_ (Before construction)

\*INSPECTION FEE: \$ \_\_\_\_\_ (Before construction)

\_\_\_\_\_  
Signature of Applicant Date

**DO NOT WRITE BELOW THIS LINE**

Action of Township: \_\_\_\_\_

Date Application Received: \_\_\_\_\_

Amount of Fees Received: \_\_\_\_\_

Date Approved: \_\_\_\_\_

\_\_\_\_\_  
TOWNSHIP OF BARNEGAT

*\*PLEASE CONTACT THE TOWNSHIP WATER AND SEWER ENGINEER BEFORE ANY CONNECTIONS ARE MADE. A 48 HOUR NOTICE MUST BE GIVEN PRIOR TO CONSTRUCTION OF ANY SANITARY SEWER SYSTEM CONNECTION OR EXTENSION.*

## **APPENDIX I**



TOWNSHIP OF BARNEGAT  
SANITARY SEWER SYSTEM  
SCHEDULE OF EQUIVALENT DWELLING UNITS

REFER TO BARNEGAT TOWNSHIP CODE, CHAPTER 74, WATER/SEWER UTILITY, FOR SCHEDULE OF  
EQUIVALENT DWELLING UNITS.

**APPENDIX II**

TOWNSHIP OF BARNEGAT  
SEWER SUPPLY SYSTEM  
FEE SCHEDULE

REFER TO BARNEGAT TOWNSHIP CODE, CHAPTER 74, WATER/SEWER UTILITY, FOR SCHEDULE OF FEES.

